

Radio ZS

Volume 79, No 6 June 2026 Junie



ICOM

HAMSHACK PRETORIA

Grootste nasionale verspreider van ICOM™ produkte
Handelaar sedert 2005

Jan (Pine) ZS6OB - 082 447 7823



IC-7760 HF/50 MHz High Power 1-200W (nuwe model)



ID-52E



IC-7610 SDR HF/50 MHz



IC-2730E VHF/UHF Dubbel band



IC-7100 HF/VHF/UHF



IC-7300 HF/50/70 MHz * 5 MHz opsie



IC-9700 VHF/UHF/1200 MHz SDR



IC-705 HF/VHF/UHF



IC-PW2 LDMOS 1 kW HF/50MHz versterker (nuutste model)

H/V 801 Netzeerol & Malmesbury Strate, Wiegate Park, Pretoria

E-pos: hamshack@gmail.com

Volledige reëks en diensbode beskikbaar
ICOM twee jaar waarborg
Skakel vir meer inligting

Lokale uit-waorborg herstelling beskikbaar

DPS: [S25-49-21-E28-16-04](https://www.dps.co.za)

Moenie van die reëks bly in voorraad



Radio ZS



The Journal of the South African Radio League
Die Tydskrif van die Suid-Afrikaanse Radioliga

“Advancing the Spirit of Amateur Radio Through Innovation”

YOU are the SARL!

Volume 79, Issue 6 - June 2026 Junie

Editor: Dennis Green, ZS4BS radiozs@sarl.org.za

In this issue

4. What's happening in June?
5. Silent Keys and Amateur Radio News
6. Our Volunteers
8. Welcome to the new Radio Amateurs
9. The 2025 SARL Awards and Trophies
11. The new ZS2BK Satellite Award
12. The IARU HF World Championship
13. The SDR Revolution
16. OrigamiSat-2 Receives Fuji-OSCAR 126 (FO-126) Designation from AMSAT
17. Satellite Shorts from All Over
19. Building a Qatar-OSCAR-100 Satellite Narrowband Transponder Ground Station
27. AMSAT-DL to Highlight QO-100 at Friedrichshafen
28. Launching Satellites With Zero Emissions
29. The Pretoria ARC May RAE – A Signal of Renewal
32. What happened on Friday 1 May at the Willows?
39. The Mast...
41. Senator Ted Cruz Praises Amateur Radio Operators for Emergency Preparedness

On the Cover. Sid Tyler, ZS5AYC receiving his Honorary Life Membership Award from Nico van Rensburg, ZS6QL

Op die Voorblad. Sid Tyler, ZS5AYC, ontvang sy Ere-Lewenslange Lidmaatskap-toekenning van Nico van Rensburg, ZS6QL

42. Ywer laat amateurradio leef
43. What Causes Lightning? The Answer Keeps Getting More Interesting
49. The ZS0BOT low-power Beacon
51. Number stations - Ghosts on the Shortwave Bands
55. The WT3J GUI-Based Morse Code Controller
57. The YL.Beam
61. The RaDAR Rally
67. A Report on the 2026 SARL National Convention
69. The May RAE on the West Coast
70. The SARL AGM on 2 May
75. Lighthouses: The Slettnes Lighthouse
78. The Museum Piece: The Radios that Started and Ended World War II in the Pacific
81. HF Update
85. The Surprisingly Long Life of the Vacuum Tube
91. FCC Approves Limited Emergency Use of 70 cm Band by AST Space-Mobile Satellites Outside the US
92. The SARL Awards Dinner
102. Multiband HF Centre-Loaded Off-Centre-Fed Dipoles
128. That is all Folks!

South African Radio League

Suid-Afrikaanse Radioliga

Founded 20 May 1925 /
Gestig 20 Mei 1925

The National Body for
Amateur Radio in South
Africa and Member Society
of IARU Region 1

Die Nasionale Liggaam vir
Amateur Radio in Suid-
Afrika en Lidvereniging van
IARU Streek 1

<https://mysarl.org.za/>

The National Amateur Radio Centre

Sender Technology Park,
Octave Street, Radiokop
PO Box / Posbus 1721,
Strubensvallei 1735
South Africa / Suid-Afrika

Office Administrator:

Kelley Dorey



Telephone: 087 822 1464
or 072 023 5995

E-mail / E-pos:

admin@sarl.org.za

President:

Guy Eales, ZS6GUY

Vice President/Vise-

President:

Phillip van Tonder, ZS6PVT

Treasurer/Tesourier

Corrie de Beer, ZS6CDB

Secretary/Sekretaris

Dennis Green, ZS4BS

Members/Lede

Rassie Erasmus, ZS1YT

Noel Hammond, ZR6DX

Chris Turner, ZS6GM

Nico van Rensburg, ZS6QL

Karel Bezuidenhout,

ZS6WN

Gary Immelman, ZS6YI

Disclaimer

The opinions expressed in this publication do not necessarily reflect the official view of the South African Radio League and the South African Radio League cannot be held responsible for incorrect information published.

What you doing in June

| Sunday | Monday | Tuesday | Wednesday | Thursday | Friday | Saturday |
|---|--|--|--|---|---|--|
| 31 Republic Day and the CQ WPX CW contest | 1  | 2 | 3 World Bicycle Day  | 4 the SARL Top Band QSO Party  | 5 World Environment Day and the SARL Top Band QSO Party | 6 the SARL Top Band QSO Party, ARRL Inter DX Digital contest and the Pretoria Boot Sale |
| 7 the SARL Top Band QSO Party and the ARRL Inter DX Digital contest | 8 World Oceans Day | 9 | 10 | 11 | 12 | 13 the ZS SOTA Weekend, Queen of the Mountains and the SARL VHF/UHF FM Mode Contest |
| 14 the ZS SOTA Weekend, Queen of the Mountains and the SARL VHF/UHF FM Mode Contest | 15 School holiday | 16 youth Day and the SARL Youth QSO Party | 17 World QRP Day  | 18 | 19 | 20 SARL Saturday 20 m Club Contest |
| 21 Winter Solstice; Father's Day  | 22 | 23 | 24 | 25 | 26 Provincial Schools close; Ham Radio FNH  | 27 Ham Radio FNH; ARRL Field Day |
| 28 Ham Radio FNH; ARRL Field Day | 29 | 30 International Asteroid Day and the end of the 2025/26 SARL Financial Year | 1 Start of the 2026/27 SARL Financial Year | 2 | 3 | 4 the SARL Newbie QSO Party  |

ZS2BL's SA Hamshack

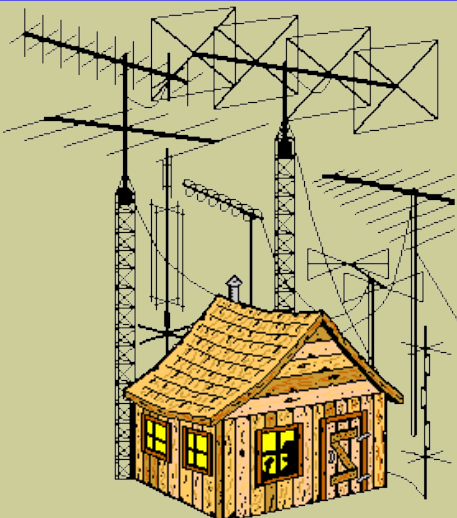

Direct importer of a wide selection of SWR meters, HF, VHF and UHF base and mobile antennas. Amateur radio transceivers, antenna analysers, etc.

Affordable shipping costs for out of town customers and subsidized shipping to SARL members.

Check out all my amateur radio goodies at

<http://www.sahamshack.co.za/index.htm>

and contact me on 072 026 8909 or zs2bl@sahamshack.co.za

They shall grow not old, as we that are left grow old,
Age shall not weary them, nor the years condemn.
At the going down of the sun and in the morning
We will remember them.

Hulle word nie oud soos ons wat bly vergrys,
Die jare sal hulle nie raak nog die tyd se eis.
En, soos die son sak of die more ontvou,
Eer hul herinnering - Ons sal onthou.

John Jack, ZS6BJJ
Norman Perelson, ZS2RI
Neels van Eeden, ZS1OB



Amateur Radio News

AMSAT SA finalises the 2026 Space Symposium date

This year the AMSAT SA Space Symposium will be held on Saturday 1 August and will again be an online event. The reason it will be online is to give as many as possible people the opportunity to attend without having to travel involving large travel cost.



The theme of the symposium is, "The new Amateur Radio World in Space" exploring the many facets of activities in the space environment. The aim is to present discussions on the practical hands-on aspects as well as emerging technologies.

Papers are invited. Radio Amateurs, Space Scientists and enthusiasts are encouraged to share their experiences and submit proposals for papers and a short summary for consideration to be included in the programme.

The Symposium is planned to run from 10:00 – 14:00 CAT (08:00 - 14:00 UTC).

Interview with the ARRL CEO: Remote Operating

ARRL CEO David Minster, NA2AA and Dick Strassburger, N9EEE, Editor of *Solid Copy*, the monthly newsletter of CWops, were guests on episode 94 of [The DX Mentor](#) (15 May 2026) for a discussion about remote operating. The show is hosted on YouTube by Bill Salyers, AJ8B.

Dick Strassburger led the discussion, which included Minster describing the contest station he

frequently operates on the Caribbean island of Bonaire, built by Noah Gottfried, K2NG/PJ4NG, as well as the remote station David Minster has helped configure and assemble. The video interview is available on YouTube at youtu.be/EZFQgMejBOY.



Public Broadcasting in South Africa

The SABC or the South African Broadcasting Corporation is the public broadcaster in South Africa and provides 19 radio stations (AM/FM) as well as six television broadcasts and three OTT Services to the general public.

Radio broadcasting in South Africa began in 1923, under the auspices of South African Railways, before three radio services were licensed: the Association of Scientific and Technical Societies (AS&TS) in Johannesburg, the Cape Peninsular Publicity Association in Cape Town and the Durban

(Continued on page 6)

(Amateur Radio News from page 5)



Corporation, which began broadcasting in 1924.

These merged into the African Broadcasting Company in 1927, owned by I.W. Schlesinger, a wealthy businessman, but on 1 August 1936, they were sold to the SABC, established that year through an Act of Parliament. The SABC took over the African Broadcasting Company's staff and assets. It maintained a state monopoly on radio until the launch in December 1979 of Capital Radio 604, then Radio 702 in 1980.

In 1975, after years of controversy over the introduction of television, the SABC was finally allowed to introduce a colour TV service, which began experimental broadcasts in the main cities on 5 May 1975, before the service went nationwide on 6 January 1976.

Television on South Africa turned 50 on Tuesday 6 January 2026.

The SABC turns 90 on Saturday 1 August 2026.

2026 FIFA World Cup

The [FIFA World Cup](#) is the quadrennial international men's football (soccer) championship contested by the national teams of the member associations of the Federation Internationale de Football Association. Jointly hosted by the United States, Mexico and Canada, the 2026 "World Soccer Tournament" will take place from 11 June to 19 July and amateur radio operators from the sixteen host cities will be active to celebrate the event: 4A1CMX Mexico City; 4A1GDL Guadalajara; 4A1MTY Monterrey; K0C Kansas City; K4C Miami; VB7F Vancouver; VC3F Toronto; W1C Boston; W2C New York/New Jersey; W4C Atlanta; W5C/D Dallas; W5C/H Houston; W6C Los Angeles; W6S San Francisco; W7C Seattle and WM3PEN Philadelphia.

Complete information, including detailed operating schedules and certificates, can be found



on <https://wc2026ses.org/>.

WARC bands

The year 1979 was 47 years ago. That was when the 12, 17 and 30-metre bands were approved for amateur radio use by that year's ITU conference (known as the World Administrative Radio Conference), with an agreement among nations that they are not to be used for radio contesting. The "WARC bands" are 12, 17 and 30 metres.

The Challenge of DXing in Africa

Ken Claerbout, K4ZW, presented "[The Challenge of DXing in Africa](#)" at the Madison DX Club. Some groups travel to put a rare country on the air for major DX contests and the experiences and advice that Ken provides may help with planning. Kudos to the [Madison DX Club](#) for putting their meetings on YouTube for anyone to benefit from — it builds their authority and brand while providing a service to the hobby.

"Africa, she is a tough country!"

Operating Tip

This is more a station building and layout tip. Magnetically coupled noise may be a problem in the rat's nest of cables you see under the average operating position. Hal Kennedy, N4GG, talked about this in his [Contest University presentation](#) and suggested some practical things to do to minimize the coupling effects from noise generators and noise conductors. Keep coax at least 15 cm away from switching power supplies of any kind. Do not bundle signal cables and power cables together. The slides are worth going through and I am looking forward to the posting of the video of the presentation.

Power Cords

Power cords and the equipment that uses them, are characterized by a standard — [IEC 60320](#). The [Digital Museum of Plugs and Sockets](#) has a page devoted to this standard, with pictures of some of the more common ones. The reason some connectors are transparent? Better to be able to note the conditions of the internal connections.



Working Groups and Coordinators

Amateur Radio Today: Hans van de Groenendaal, ZS6AKV artoday@sarl.org.za.

ART Relays: Louis Veldkamp, ZR4DJL and Andy Cairns, ZS6ADY

Awards: Tjerk Lammers, ZS1J

Contest WG: Johan Bezuidenhout, ZS6JBZ; Gerhard Coetzee; ZS3TG; Phillip van Tonder, ZS6PVT; Phillip Fischer, ZS6FY; Danie Schnetler, ZS6DPS

Database: Colin de Villiers, ZS6COL

Forum: Bradley Phillips, ZS5Z; Roger Conroy, ZR3RC and Andy Cairns, ZS6A

IARUMS: Vacant

QSL Manager: Gert du Plessis, ZR6GRT

RAE and Training: Donovan van Loggerenberg, ZS2DL rae@sarl.org.za

Regulatory WG: Hans van de Groenendaal, ZS6AKV; Leon Lessing, ZS6LMG; James Archibald, ZS6NS and Peter Leonard, ZS5PL

Reno Faber Station:

Repeater Co-ordination: Philip van Tonder, ZS6PVT

SARL Beacon Project Manager: Brian Jacobs, ZS6YZ

SARL Hamnet: Brian Jacobs, ZS6YZ; Michael Taylor, ZS1MJT; Andrew Gray, ZS2G; Rickus de Lange, ZS4A; Keith Lowes, ZS5WFD; Gert Botha, ZS6GC and Leon Lessing, ZS6LMG

SARL/ICASA Liaison: Hans van de Groenendaal, ZS6AKV; Nico van Rensburg, ZS6QL and Colin de Villiers, ZS6COL

SARL News/SARL Nuus: Dennis Green, ZS4BS; Dave Reece, ZS1DFR; Rory Norton, ZS2BL; Andy Cairns, ZS6ADY; Vivian Dold, ZS6VD; Herman Erasmus, ZS6CTA; Paul Johnson, ZS1S; Irene Myburg, ZS6IEA; Deon Erwin, ZS1ZL; Christo de Witt, ZS3CDW, Hannes Enslin, ZS6JDE and Kevern Burger, ZR2BK

SARL VHF and Above Records: Paul Smit, ZS6NK

Swap Shop: Rassie Erasmus, ZS1YT

Youth/Jeug:

Radio ZS Awards

The Gary Immelman RA Heritage Award Floating Trophy awarded by the SARL Council for the best article of a historic nature describing an event that occurred more than five years previously or an interesting personality that has played an important part in the development of Amateur Radio in years gone by. Donated by Gary 1993.



The JJ Pienaar Trophy awarded by the Editor for the best article published in Radio ZS during the past year.

The Radio ZS Shield awarded by the Editor to a South African Radio League affiliated Club or member who best supported Radio ZS during the year. Donated by the Port Elizabeth Branch in 1966.

Radio ZS

Radio ZS is a forum for South African Radio League members to share their amateur radio experiments, experiences, opinions and news. Manuscripts with drawings and/or photos are always welcome and will be considered for publication. Articles on e-mail are especially welcome. Material may be submitted in MS Word, Open Office or rtf format, using Calibri 12 pt and English (South Africa). Material may be e-mailed to radiozs@sarl.org.za. The League cannot be responsible for loss or damage to any material. <https://mysarl.org.za/radio-zs-archives/>.

Use of Articles in Radio ZS. Other IARU Member Societies may on written approval from the author and the editor of Radio ZS, reproduce material published in paper or digital form, for which the publishing author holds the copyright.

Such approval shall not unreasonably be withheld. Material taken for other Member Societies' publications in this way shall have a source and originator acknowledgement included on publication.



Welcome to the new Radio Amateurs

The May 2026 RAE

Mr AMK Klazinga, ZR1AK
 Mr JJ Giffard, ZR1JJ
 Mr JP Celliers, ZR1JPC
 Mr JJ Schep, ZR1JS
 Mr DES Smith, ZR1TL
 Mr CS Giddy, ZR1UWU
 Mr BFJ Krog, ZS1BFJ
 Mr JA Claasen, ZS1CJA
 Mr CVN van Niekerk, ZS1CVN
 Mr GJ Cross, ZS1DCE
 Mr E van Zyl, ZS1EVZ
 Mr GF Da Silva, ZS1GDS
 Mr N Roux, ZS1GFO
 Mr GJ Steyn, ZS1GJS
 Mr GL Hanekom, ZS1GLH
 Mr JA Braun, ZS1JBN
 Mr KA Malinaric, ZS1KMA
 Mr LU Buis, ZS1LAZ
 Mr MA Hartley, ZS1MIK
 Ms A Pienaar, ZS1MR
 Mr ND Braun, ZS1NDB
 Mr N Smith, ZS1NEI
 Mr RC Mayhew, ZS1RCM
 Mr JMB Bester, ZS1UPA
 Mr D Green, ZS1ZAG
 Mr SL Louw, ZS2OBI
 Mr SC Van Staden, ZS2SHR
 Dr T Gundu, ZS2TAP
 Mr DJ Botha, ZS2TT
 Mrs T Matthee, ZS2TW
 Mr AL Louw, ZS2WAT
 Mr SD Swanepoel, ZR5SDS
 Mr I Pillay, ZS5BB
 Mr JR Peet, ZS5JRP
 Mr F Mansur, ZS5MF
 Mr ASF Fletcher, ZS5RSQ
 Mr DJ Van den Berg, ZR6DJV



Mr K Altaki, ZR6KT
 Mr KM Mekgwe, ZR6MZ
 Mr R Naicker, ZR6ROD
 Mr D Lombaard, ZS6ABD
 Mrs AN Naicker, ZS6AMN
 Mr B Illing, ZS6BIL
 Mr R Budai, ZS6BUD
 Miss CJ Robinson, ZS6CVO
 Mr D Byjnal, ZS6DBZ
 Mr BG Forbes, ZS6FBZ
 Mr F de Beer, ZS6FCD
 Dr GL Van Harmelen, ZS6GRD
 Mr G van Schalkwyk, ZS6GVS
 Mr PL Fryer, ZS6HMF
 Mr J Morkel, ZS6HW
 Mrs L Groenleer, ZS6ISA
 Mr J Smith, ZS6JSX
 Mr MJJRoux, ZS6JXR
 Mr KS van Oldenborgh, ZS6KVO
 Mr P Piek, ZS6PWA
 Mr Q Nel, ZS6QN
 Mr R Byjnal, ZS6RBZ
 Mr R Sylvester, ZS6RSZ
 Mr PJ Solomon, ZS6SOL
 Mr S Groenleer, ZS6SVE
 Mrs SS Muller, ZS6TMR
 Mr MA van Zyl, ZS6TVZ
 Mr WC Victor, ZS6WCV



The 2025 SARL Awards and Trophies

Handed over the 2026 SARL Awards Dinner

SARL Honours

Honorary Life Membership

Sid Tyler, ZS5AYC

The Willie Wilson Gold Badge

Adele Tyler, ZS5APT

Michael Taylor, ZS1MJT

Christo Kriek, ZR6LJK

Gert Botha, ZS6GC

Keith Barker, ZS6HI

The Koos & Annie van der Merwe Platinum Award

Theunis Potgieter, ZS2EC

Dave Higgs, ZS2DH

The Koos & Annie van der Merwe Gold Award

Tony Allen, ZR2TX

Chris Scarr, ZS2AAW

Andrew Gray, ZS2G

Glen Cummings, ZS2GV

Jaco Louis Kruger, ZS6JLK

Devon Person, ZS6DEV

The Jack Twine Merit Award

Neil Beattie, ZR1ABO

Christo Swart, ZS1CBY

David Theron, ZS1GA

Neville Gleeson, ZS1NEV

Odette Vosloo, ZS2OD

Andrew Boweden, ZS2AFB

Eric Hosten, ZS2ECH

Paul Schoeman, ZS2PS

Vaughan Rizzo, ZS2VR

The SARL Hall of Fame

Jan Botha, ZS4JAN

Technical Awards

The Icom Excellence Award

Anton Janovsky

The Tinus Lange 7066 Technical Excellence Award

Viv Dold, ZS6VD

The SAATI Technology Award

Gert Botha, ZS6GC

Operating Awards

The Barney Joel Trophy (HF Mobile)

Nico van Gijsen, ZS1NR

The Bert Buckley Six Metre Trophy

Paul Smit, ZS6NK. 200 DXCC Entities worked and confirmed in 2025 - the first ZS to achieve it.

Arthur Hemsley 2 metre Trophy

Bernie vd Walt, ZS4TX. 2 metre EME and TEP QSOs from the Botswana, Namibia and Angola DXpedition. A new ZS TEP Record with LZ1DX on 2 metres Q65 from ZS4TX/6 in KG47LI with LZ1DX in KN22TK on 20 October 2025. A distance of 7 253 kilometres.

Radio ZS Two Metre Floating Trophy

Bernie vd Walt, ZS4TX. A 2 metre Q65 EME contact with NH6V in Hawaii on 11 June 2025. KG30BX to BL20BB = 19 020 kilometres

Joseph White Plaque

Bernie vd Walt, ZS4TX. Set a world record on 23 cm (1,3 GHz.)

The Heritage on the Air Award

Activators: Adele Tyler, ZS5APT and Sid Tyler, ZS5AYC

Chaser: Mark Walker, ZS6MDX

The Brian Jones, ZS6BV, SOTA ZS Award

Petrus Lotriet, ZU3PL

The Tyler SOTA Excellence Award

(to be awarded at the discretion of Sid ZS5AYC & Adele ZS5APT)

Brandon Zietsman, ZS6LZ

The 2025 Queen of the Mountains

Esmarie Lotriet, ZS3EL

Sam Joubert, ZS3SD

Adele Morton, ZS5ALM

Louise Larsen, ZS5BSR

Magda Swart, ZS6MMS

(Continued on page 10)

(SARL Awards and Trophies from page 9)

The ZS-SOTA Ten Regions Challenge

(Working one peak in each of the 10 ZS regions)

Jan Lavicka OK2PDT

Esmarie Lotriet ZS3EL

Peet Lotriet ZS3PL

Nico Oelofse ZS4N

Warren Akerman ZS6AKW/4

Christo Avenant, ZS6CPA

ZS-SOTA DX Challenge

Adele Tyler, ZS5APT

Sid Tyler, ZS5AYC

Philip Fischer, ZS6FY

Brandon Zietsman, ZS6LZ

Brandon Zietsman, ZS6LZ

Sid Tyler, ZS5AYC

Adele Tyler, ZS5APT

Phillip Fischer, ZS6FY

Graham Busse, ZS6GL1

Radio ZS

Gary Immelman RA Heritage Award Floating Trophy

The article "The history of ZS2BO and ZS2VDL with the PEARS VHF/UHF Contest" (Radio ZS February 2025) - Kevern Burger, ZR2BK

JJ Pienaar Trophy

"The Activation of Mt Durnford." Radio ZS August 2025 - Alan Ridgard, ZR6AQV

"The 2025 Lesotho SOTA/POTA Micro DXpedition" Radio ZS December 2025, "Journal: 2025 Lesotho SOTA DXpedition" Radio ZS January 2026 - Brandon Zietsman, ZS6LZ

Radio ZS Shield

Brandon Zietsman, ZS6LZ

Excellence Awards

The Arland Ussher Gold Pen Award

Ian Genis, ZS6IAI

The Class B RAE Certificate

Timothe Gourdain, ZU6TG/ZR6GOU

The Hamnet Shield

Michael Taylor, ZS1MJT

Danie vd Merwe, ZS1OSS

Shawn Duncan-Smith, ZS1LED

Ian Bradley, ZS1BR

SARL Hammies Youth Development Excellence Award

Lunga Nqini, ZS2LN

SARL Young Amateur Excellence Award

Petrus Lotriet, ZU3PL

Rulhof vd Merwe, ZS4RM

SARL Club Excellence Award

The Secunda ARC

SARL Certificate of Recognition

Odette Vosloo, ZS2OD

Patricia Kruger ZS2PTY

Gert Schoeman, ZS2GS

Beverley Higgs

Eugenie Burger

Hendrik Henning, ZS6HJH

Contest Awards

Silent Keys Memorial Trophy SSB.

The West Rand ARC

Joseph White Trophy

Deon Fraser, ZS5DCF

The SARL Digital Trophy

The West Rand ARC

The Silent Keys Memorial Trophy CW

The West Rand ARC

The Anon Trophy.

Charles le Roux, ZS1CF

The HOS Trough (Honourable Operating Secretary)

The West Rand ARC

The Fred Mills Trophy

Philip Fischer, ZS5FY

The SAWRC Trophy

Veronica Kotze, ZR6VTK

(Continued on page 11)

(SARL Awards and Trophies from page 10)

The Club Participation Award (Branch Participant Trophy)

The West Rand ARC

The SARL 80 m Championship Trophy (SARL Wednesday 80 m Club Sprint)

The West Rand ARC

The SARL 40 m Club Championship (SARL Saturday 40 m Club Sprint)

The West Rand ARC

The SARL QRP Contest Awards

Grand Champion 2025: Phillip Fischer, ZS6FY

CW Mode Champion: Eddie Leighton, ZS6BNE

Chaser Champion – Andre Fransman, ZS1F

FT Mode Champion – Paul Tye, ZS1PTY

The new ZS2BK Satellite Award

QX-PE May 2026

A new award has been created by the South African Radio League, called the ZS2BK Satellite Award. The award will be presented annually by the South African Radio League at the Annual Awards Gala Dinner to a worthy recipient.

This new award was created due to the many achievements that Andre Van Deventer, ZS2BK has made with working satellites, including a DXCC

Award via Satellite. Andre has made a massive contribution to amateur radio in South Africa over the many years, and having achieved this milestone is commendable.

On Saturday 2 May 2026, a copy of the award was handed over to Andre in Port Elizabeth. The other copy of the award will now live in the National Amateur Radio Centre.



Kevern Burger, ZR2BK; Nico van Rensburg, ZS6QL; Andre van Deventer, ZS2BK with his copy of the trophy; Gary Immelman, ZS6YI and Dave Higgs, ZS2DH

The IARU HF World Championship

<https://www.arrl.org/iaru-hf-world-championship>



Contest Objective: To support amateur self-training in radiocommunications including improving amateur operating skills, conducting technical investigations and intercommunicating with other amateurs around the world, especially IARU member society headquarters stations.

Contest Period: Second full weekend in July. Begins 12:00 UTC on Saturday 11 July and runs through to 11:59 UTC on Sunday 12 July. There is no operating time restriction for stations in any category.

Log Deadline: Upload your log at contest-log-submission.arrl.org no later than **SEVEN (7)** days after the contest is over at 11:59 UTC. Paper log forms are available at the [IARU HF Championship](https://www.arrl.org/iaru-hf-world-championship) web page.

Bands and Modes: Use only the 160, 80, 40, 20, 15 and 10 metres. Both phone and CW may be used. Contact stations only once per band and mode.

Categories: Single Operator and Single Operator Unlimited stations in any power category can also enter as Mixed-Mode, CW-Only, or Phone-Only. Multi-operator stations may only enter as Mixed-Mode. See the Special Rules and Entry Categories sections for details.

Contacts: All stations may contact any other station. Stations may be contacted once per band on each mode.

Exchange: All stations send a signal report and ITU zone. Headquarters stations operated by an IARU National Society send the abbreviation for their society instead of zone. (i.e. ZS0HQ sends SARL). Stations operated by the IARU Administrative Council and the three IARU regional Executive committees send "AC," "R1," "R2" and "R3" as appropriate. A link to the ITU zone maps is provided below.

This is a typical contest contact:

CQing Station: CQ test from ZS3I

Answering Station: G3BJ

CQer: G3BJ 59 59 (South Africa is in ITU Zone 59)

Answer: 59 27

CQer: Thanks, CQ test from ZS3I

Or

CQing HQ Station: CQ TEST DE ZS9HQ

Answering Station: N1SFE

HQ station: N1SFE 599 SARL

Answer: 599 8

HQ station: TU ZS9HQ

As the answering station, it is not necessary to send the CQing station's call before the exchange unless you think there might be some confusion about which station you are responding to.

Scoring: The QSO point value of a contact depends on the location of the station — see the special scoring rules for complete information. To calculate your final score, multiply the total QSO points by the number of ITU zones and official IARU stations as described in the Special Rules.

Feedback about the contest: Send us your stories and photos! Tell us what fun you had, how you did and what challenges you faced at the ARRL Contest Programme's "[Soapbox](https://www.arrl.org/soapbox)" page.

Additional Resources: [ITU Zone Map from EI8IC](https://www.itu.int/itu-t/zone-map/)

All contest queries should be directed to contests@arrl.org.

The rules allow for 12 stations using ZS9HQ at the same time during the contest - ZS9HQ CW 160; ZS9HQ SSB 160; ZS9HQ CW 80; ZS9HQ SSB 80; ZS9HQ CW 40; ZS9HQ SSB 40; ZS9HQ CW 20; ZS9HQ SSB 20; ZS9HQ CW 15 m; ZS9HQ SSB 15; ZS9HQ CW 10 m and ZS9HQ SSB 10 m.

The World Radio Sport Team Championship

The World Radio Sport Team Championship, known as WRTC will take place from 8 to 13 July 2026 in the East Anglia region of the United Kingdom.

The 50 teams will be located in the counties of Suffolk, Norfolk and Cambridgeshire and they will participate in the 2026 IARU HF World Championship on 11 and 12 July. The call signs to be used by these stations will be drawn on Saturday morning 11 July.



The SDR Revolution

Stewart Clark, ZR1WT

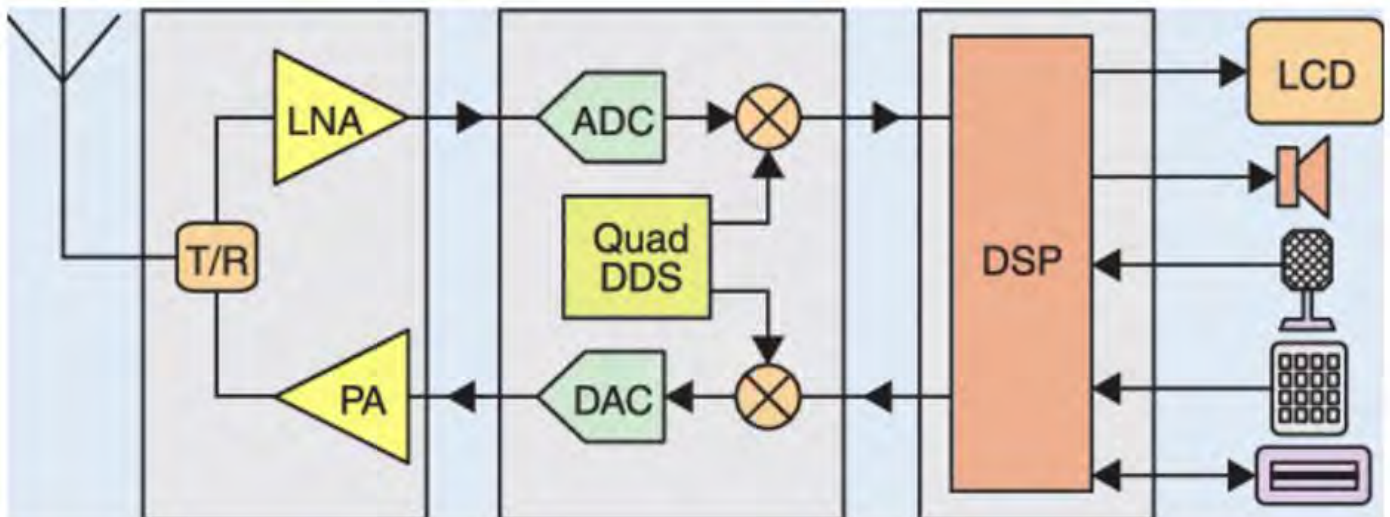

What Is SDR - A Quick Refresher

For those newer to the topic, let's start with the fundamentals. A traditional radio receiver is built around hardware: mixers, filters, amplifiers, demodulators - all of them analogue circuits, fixed at the time of manufacture. Change the mode, change the band and you either need a different radio or a whole lot of switching circuitry.

Software-Defined Radio turns that model on its head. The idea is elegant: get the radio frequency signal into the digital domain as early as possible - right at the antenna if you can - and then let software do the rest. Filtering, demodulation, decoding - all of it becomes software running on a general-purpose processor or an FPGA (Field-Programmable Gate Array). Need a new mode? Update the software. Support a new digital protocol invented last year? Update the software to handle it.

The concept is not new - the term was coined in the 1990s by Joseph Mitola at the US Army Research Laboratory - but the hardware to make it affordable for the everyday amateur has only matured in the last decade. And right now, in 2026, we are witnessing an acceleration in SDR capability that would have seemed remarkable even five years ago.

The RTL-SDR: The Dongle That Started a Revolution

The story of consumer SDR really begins with a happy accident. Around 2010, a group of hackers discovered that a cheap DVB-T television dongle -

built around the Realtek RTL2832U chip - could be persuaded to output raw I/Q baseband samples directly to a PC. In other words, instead of receiving digital television, it could act as a wideband software-defined receiver covering roughly 24 MHz all the way up to 1,7 GHz.

The chip was never designed for this, but it worked. And because these dongles were mass-produced for the consumer television market, they were astonishingly cheap - well under \$10 US when bought in bulk. Purpose-built RTL-SDR units with better shielding, stability and RF front-ends now sell for around \$30. For that price, a licensed amateur can receive aircraft ADS-B transponders, weather satellites, trunked radio systems, NOAA satellite imagery and of course the entire HF spectrum - just with some software on the PC. That dongle democratized radio experimentation in a way nothing else has.

Stepping Up: The RX888 and the Era of Direct Sampling

But the RTL-SDR, clever as it is, has limitations. Its dynamic range is modest, its noise floor not particularly low.

Enter the RX888 and its successors. This board uses a 16-bit analogue-to-digital converter - a significant step up from the 8-bit resolution of the RTL - and supports direct sampling across the entire HF spectrum from 1 kHz all the way to 64 MHz. At that bandwidth, a single RX888 can digitise the entire shortwave spectrum simultaneously. Every

(Continued on page 14)

(Off-Centre-Fed Dipoles from page 13)

amateur band from 160 to 6 metres - all of it, at once, in one box, at one moment in time.

The implications are profound. Want to watch propagation across multiple bands simultaneously? Done. Want to run a reverse beacon network that spots every CW signal on every HF band at the same time? That's now a single-box operation.

The Web-888: A New Benchmark for Internet-Accessible SDR

One of the most exciting recent developments is the Web-888, a receiver that builds directly on the RX888 design philosophy but integrates a complete networked SDR server on a single board - combining an FPGA (Field-Programmable Gate Array) for digital signal processing with an ARM processor and a self-contained web interface. No external computer required.

With a 16-bit ADC running at tuneable sample rates, the Web-888 covers HF from 1 kHz to 62 MHz and extends up into VHF air band territory at 118 to 145 MHz. Crucially, it can operate 13 simultaneous receive channels with 13 independent waterfall displays - thirteen users, all tuned to different frequencies, all on a single piece of hardware drawing modest power.

The design borrows the best ideas from earlier SDRs - the RF front-end philosophy of the RX888, the web interface paradigm of the KiwiSDR, the FPGA architecture of the Red Pitaya - and blends

them into something coherent and capable.

New extensions are being actively developed: a CW skimmer, an HF DL decoder for receiving aeronautical high-frequency data link traffic and FT8 and WSPR skimmers that run continuously, capturing and spotting every decodable signal on every designated frequency, around the clock. For amateurs interested in propagation monitoring, this is a remarkably powerful tool.

OpenWebRX and the Networked SDR Ecosystem

Of course, hardware is only half the story. The software ecosystem around SDR has matured enormously.

OpenWebRX is one of the flagship open-source projects in this space - a web-based SDR interface that allows any browser-equipped device to tune, listen to and decode signals from a remotely hosted SDR receiver. No software installation, no drivers, no special hardware at the client end. Just a browser.

OpenWebRX supports a remarkable range of digital mode decoders built directly into the interface: FT8, FT4, JS8Call, WSPR, APRS, D-STAR, DMR, RTTY, SSTV and more. When you connect to an OpenWebRX server, you are not just listening - you are decoding, logging and in some cases automatically uploading spots to aggregation networks.

PhantomSDR is another new entrant in this

(Continued on page 15)

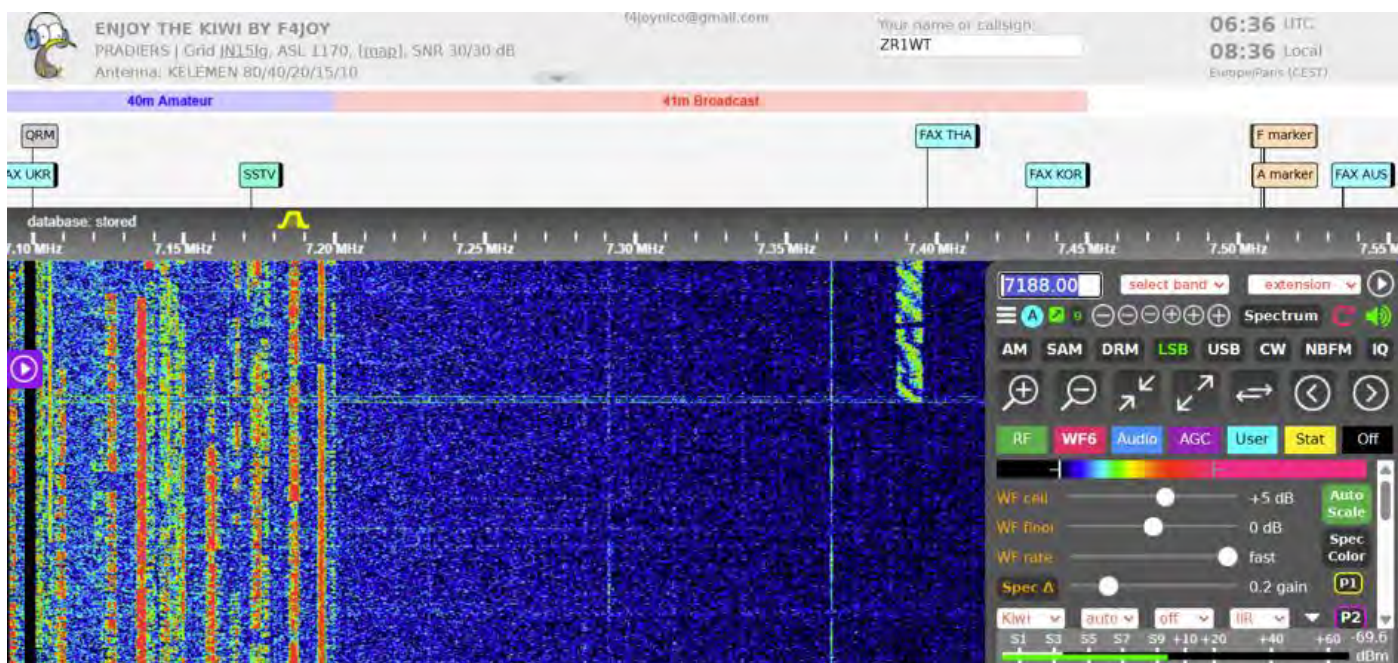

Here is a site (Auvergne in France) tuned to 7 188 and LSB. (A list of URLs is given at the end)

(The SDR Revolution from page 14)

space, designed specifically to handle the enormous bandwidth of devices like the RX888 efficiently - offloading much of the processing to the client's web browser using **WebAssembly**, so the server can support hundreds or even thousands of simultaneous users without being overwhelmed.

There are currently over 2 400 publicly accessible SDR receivers listed on global maps - **KiwiSDRs**, **OpenWebRX** nodes, **WebSDR** stations and now **Web-888s**. As a South African amateur, you can open a browser and tune an antenna in Japan, listen to the 40-metre band from a receiver in the Netherlands, or check HF propagation into Europe from a station in Australia. The world's shortwave spectrum, available on demand, from your desk.

The AI Frontier: Machine Learning Meets RF

Now here is where things get genuinely fascinating - and where we are entering territory that would have been science fiction a decade ago. Researchers are actively applying machine learning and deep learning to SDR signal processing and the results are impressive.

A deep neural network published in research last year demonstrated the ability to automatically classify 160 different shortwave signal modes - covering the vast majority of signals found in the HF spectrum - with a classification accuracy of 90% and a top-3 accuracy of 95%, using just one second of signal observation. One second. That system can look at a waterfall, pick out an unknown signal and tell you whether it is SSB, RTTY, Pactor, an HF DL burst, a numbers station, a digital broadcast, or any of another 155 modes - faster than any operator could even begin to recognise it by ear.

These AI models are being deployed directly inside SDR platforms for real-time signal processing tasks: automatic signal detection, classification and noise reduction. The intelligent SDR system can adaptively adjust its parameters based on prevailing radio conditions, optimising performance without manual intervention.

At the 2025 New England Software-Defined Radio Workshop - one of the premier annual gatherings in this field - researchers from companies like **DeepSig** presented work on what they call "RF machine learning beyond signal

classification." The themes included generative AI for radio channel modelling, fully learned communications waveforms - where even the modulation scheme itself is designed by a neural network rather than a human engineer - and machine learning frameworks for spectrum sensing in congested, contested RF environments. The direction is clear: software-defined radio is becoming software-intelligent radio.

For the amateur community, near-term practical applications include automated noise floor monitoring, intelligent noise blankers that learn your local interference environment and contest logging tools that can identify call signs and exchange information directly from audio without the operator typing anything.

Cognitive Radio and Dynamic Spectrum Access

Zooming out slightly, SDR is also the enabling technology for what engineers call cognitive radio - radios that are aware of their spectral environment and can dynamically adapt their operating frequency, power and modulation to avoid interference and make more efficient use of available spectrum.

Practical SDR for the South African Amateur

Let us bring this back to the practical. What does all of this mean for us?

If you do not yet have an SDR receiver, the entry point has never been lower. A purpose-built RTL-SDR unit for around R700 gives you a wideband receiver capable of covering VHF, UHF, aircraft bands, weather satellites and HF. Pair it with PC software e.g. **SDRConsole**, **SDR#** or **GQRX** software on a laptop or **Raspberry Pi** and you have a formidable monitoring station.

If you want to explore HF direct sampling, the **RX888 Mk II** is available locally (see link below) for about R5 000 and with **OpenWebRX** or **PhantomSDR** running on even a modest machine, you can host your own publicly accessible SDR node - contributing to the global network of remotely accessible receivers.

For those interested in the cutting edge, the Web-888 represents the current state of the art for a self-contained, networked HF/VHF SDR and the KiwiSDR - now in its second generation - remains a

(Continued on page 16)

(The SDR Revolution from page 15)

benchmark for integration of decoding extensions, TDoA geolocation and the established Kiwi software ecosystem.

And for the experimenters among you - the builders and the coders - the SDR ecosystem has never been more open. **GNU Radio**, the open-source signal processing framework, supports everything from simple FM demodulation to complex custom waveform development. The **ADALM PlutoSDR** from Analog Devices gives you a full transmit-and-receive SDR platform for exploring digital modes, spread spectrum and even your own prototype waveforms. The tools are there. The community is active. The barriers are low.

Summary

What began as a quirk of a cheap TV dongle has grown into a technology that is reshaping how professionals, researchers and amateurs alike think about radio.

We are living in the most capable era for radio experimentation in the history of the hobby. The hardware is affordable. The software is free and powerful. The global community of SDR developers is growing. And increasingly, artificial intelligence is being woven into the fabric of how these systems perceive, classify and adapt to the radio environment around them.

Where to Buy

RTL-SDR, RX-888 SDR and ADALM Pluto SDR are all available locally from <https://www.giga.co.za/>.

Receivers to try

Here are 10 receivers you can open right now in

any browser - no software needed, just click and tune.

Master Index Sites (start here to find hundreds more)

1. KiwiSDR World List & Map - the mothership, live list of every public KiwiSDR sorted by SNR <http://rx.kiwisdr.com>
2. rx-tx.info Global SDR Map - interactive map of KiwiSDRs, OpenWebRX and WebSDR nodes worldwide <https://rx-tx.info/map-sdr-points>
3. WebSDR.org - the original public WebSDR index, running for over two decades <http://websdr.org>
4. Receiverbook.de - community-curated directory with descriptions and capabilities listed <https://www.receiverbook.de>
5. Skywave Linux SDR List - auto-updating, sorted by SNR, includes best-performing KiwiSDRs <https://skywavelinux.com/best-sdrservers.html>

Specific Receivers Worth Tuning (*good antennas, low noise floors*)

6. Tavistock, Devon, UK - KiwiSDR 2, excellent 0–30 MHz HF coverage, GPS-locked <http://82.69.125.202:8073>
7. Netherlands - PE1OPQ - KiwiSDR, great for 40/20 m European paths from ZS <http://radio-tpot.proxy.kiwisdr.com>
8. Hondon Valley, Spain - EA5JGN - KiwiSDR, consistently high SNR, good southern European coverage <http://ei2hh.proxy.kiwisdr.com>
9. Stockholm Archipelago, Sweden - KiwiSDR 2, excellent for checking aurora-affected propagation <http://22639.proxy.kiwisdr.com>
10. University of Twente, Netherlands - one of the most famous and long-running WebSDRs in the world, covering 0 – 29 MHz with a large wideband antenna <http://websdr.ewi.utwente.nl:8901>

OrigamiSat-2 Receives Fuji-OSCAR 126 (FO-126)

Designation from AMSAT

AMSAT News Service

OrigamiSat-2, one of eight satellites launched aboard Rocket Lab's Kakushin Rising mission for JAXA on 23 April 2026, has now received an official OSCAR designation from AMSAT. Developed by the Institute of Science Tokyo, the satellite has been assigned the designation Fuji-OSCAR 126 (FO-126)

following a request submitted through the Japan Amateur Satellite Association (JAMSAT). The announcement came after satellite teams confirmed successful deployment and initial on-orbit operations.

(Continued on page 17)



Reception of a 5,84 GHz CW signal from Fuji-OSCAR 126 (FO-126) displayed on an Icom IC-905. [Credit: JA10GZ]

(Fuji-OSCAR 126 from page 16)

The 3U CubeSat was designed to demonstrate lightweight deployable membrane antenna technology and promote amateur use of the 5,8 GHz band. Mission goals include testing a high-gain deployable reflector array antenna, demonstrating its performance in orbit and helping establish methods for future advanced satellite systems. OrigamiSat-2 carries both UHF and C-band transmitters and aims to expand amateur radio experimentation beyond traditional VHF and UHF operations.

IARU coordination lists downlinks on 437,505 MHz and 5 840,000 MHz. The satellite supports CW and digital modes, including higher-speed data experiments over its 5,8 GHz link. Project information released by the team indicates a desire to openly share reception techniques and

operational status with amateur operators, encouraging wider participation in receiving and decoding signals from the spacecraft.

Reports from the satellite team indicate the 5,8 GHz downlink has already been confirmed operational. Amateur satellite observers have expressed interest in monitoring activity from outside Japan as additional operational details become available. OrigamiSat-2 now joins the long-running OSCAR satellite tradition under its new designation, Fuji-OSCAR 126, continuing the international partnership between satellite developers and the amateur radio community.

[ANS thanks Drew Glasbrenner, KO4MA, AMSAT President / OSCAR Number Administrator and Shiro Sakai, JH4PHW, JAMSAT President, for the above information]

Satellite Shorts from All Over

AMSAT News Service

SpaceX successfully launched the first Version 3 Starship vehicle on May 22 from Starbase, Texas, during a major test flight of the company's next-generation heavy-lift launch system. During the Flight 12 mission, the Super Heavy booster and Starship upper stage separated successfully after ascent, although both

stages experienced individual Raptor engine shutdowns during flight. Despite the engine issues, Starship continued on a near-planned suborbital trajectory, deployed 20 Starlink mass simulators along with two experimental "Dodger Dogs" spacecraft and transmitted video from space.

(Continued on page 18)

(SARL Awards and Trophies from page 17)

SpaceX also completed a successful re-entry and soft splashdown of Starship in the Indian Ocean after approximately 66 and one-half minutes of flight, although the vehicle later tipped over and exploded as expected after landing. The upgraded Version 3 design includes major improvements to both the booster and upper stage and is expected to support future orbital payload launches, Starlink deployment missions and the Human Landing System being developed for NASA's Artemis program. NASA Administrator Jared Isaacman attended the launch and later congratulated SpaceX and Elon Musk on what he described as a major step toward future Moon and Mars missions. (ANS thanks SpaceNews for the above information).

A newly released video from the YouTube channel [Heriton](#) revisits the unusual history of AMSAT OSCAR 7 (AO-7), the amateur radio satellite launched in 1974 that unexpectedly returned to operation after more than two decades of silence. The video recounts how AO-7 ceased transmitting in 1981 after a battery failure led operators to declare the spacecraft inactive. In June 2002, amateur radio operators discovered that AO-7 had resumed operation while in sunlight, likely because long-term changes inside the failed battery pack removed the electrical short that had disabled it. AO-7 remains one of amateur radio's most enduring engineering stories and is still active today. Heriton combines historical footage, narration and technical background to introduce the satellite's story to a broader audience. The complete video, "This Cold War Satellite Was Dead for 21 Years. Then It Started Transmitting Again," can be viewed at <https://www.youtube.com/watch?v=vDBBmITGtnQ>. (ANS thanks the Heriton YouTube channel for the above information).

The Solar wind Magnetosphere Ionosphere Link Explorer (SMILE) spacecraft successfully launched aboard a Vega-C rocket from Europe's Spaceport in French Guiana on 19 May, beginning a joint mission between the European Space Agency and the Chinese Academy of Sciences. The mission is designed to improve understanding of solar storms, geomagnetic disturbances and the effects

of space weather on Earth and spacecraft systems. SMILE will become the first mission to observe Earth's magnetic shield using X-ray imaging, allowing scientists to study how the solar wind interacts with the magnetosphere. The spacecraft will also use ultraviolet imaging to continuously observe auroral activity for periods of up to 45 hours. During the coming weeks, SMILE will gradually raise its orbit through a series of engine burns before beginning scientific operations in July. Scientists hope the mission's observations will improve future models of Earth's magnetic environment and help protect satellites and astronauts from space weather effects. (ANS thanks the European Space Agency for the above information).

NASA engineers have successfully tested a prototype of a lithium-fed nuclear electric propulsion system that could one day help power human missions to Mars. During testing at NASA's Jet Propulsion Laboratory, the experimental thruster reached 120 kilowatts, the highest power level ever achieved in a US electric propulsion test. Unlike conventional chemical rockets, electric propulsion systems use electromagnetic forces to accelerate propellant and can operate with dramatically improved efficiency. The new magneto plasma-dynamic thruster uses lithium metal vapor and is designed to eventually pair with megawatt-class nuclear power systems for deep-space travel. During five test firings, engineers observed temperatures above 5,000 degrees Fahrenheit as the prototype produced a bright red exhaust plume. NASA researchers hope future versions of the system could support larger payloads and faster crewed missions to Mars. (ANS thanks Gizmodo for the above information).

US Space Command has launched a new series of classified wargames called Apollo Insight, bringing together military experts and commercial space companies to examine potential threats in orbit. The first tabletop exercise focused on a simulated scenario involving a nuclear payload in low Earth orbit and its potential consequences for space operations. Officials said a nuclear detonation in orbit could destroy or disable thousands of

(Continued on page 31)

Building a Qatar-OSCAR-100 Satellite Narrowband Transponder Ground Station

Kevin Turner, ZS6KAT



Image courtesy of [Es'hail 2/AMSAT P4A \(QO 100, Qatar-OSCAR 100\) - Gunter's Space Page](#)

1. Introduction

Having recently moved into a smaller, suburban home, I, like numerous other radio amateurs, have been forced to consider the use of smaller, less efficient HF antenna systems. Such downsizing evokes a sad feeling to which many amateurs with prior large-scale antenna experience will attest.

Gone are the tri-band quad and full sized 80 m / multiband inverted V and in has come a rotatable, tuneable, Magnetic Loop antenna. Gone entirely is my ability to transmit on 80 m because the magnetic loop only works between 40 and 10 m.

Being a long-time shortwave listener and HF DXer of 42 years, this has not been an easy transition to accept. With HOA rules tightening and man-made interference on the increase, HF operation has become harder to enjoy. Let us face it, despite all the encouraging literature on stealth antennas and QRP operation, what is really required for top notch HF communications, is a large property, high gain antennas, increased distance between neighbouring backup power systems and a higher than average transmit power level. Sadly, not handkerchief sized gardens, debilitating HOA rules and grumpy neighbours. It is with all these considerations in mind that I became determined to put on my thinking cap and come up with a suitable alternative.

The purpose of this article, therefore, is to share the solution I came up with, how I executed it and just how thrilled I have been with the results. The mix of narrative and technical presentation is intentional. Through this approach I sincerely hope that the following pages will inspire other “space-constrained” amateurs not to give up but to become “Space” savvy and adopt a similar path to mine.

2. What is the Es'hail 2 / Qatar-OSCAR 100 Geostationary Satellite?

As already indicated, HF radio operations have taken up most of my free time for the past 42 years. They say it is hard to teach an old dog new tricks. I fell squarely into the “old dog” category because I found it so difficult to believe there was any other field that could be as interesting and rewarding. To be honest, I was starting to wonder whether I had actually done the right thing by moving into this particular home

But then one fine day last year at the West Rand Flea Market, I spotted the club Es'hail Qatar QO-100 satellite dish and out of random curiosity found myself engaged in a surprisingly interesting conversation with my friend Henry, ZS6MC about the virtues of working the world (or at least half of

(Continued on page 20)

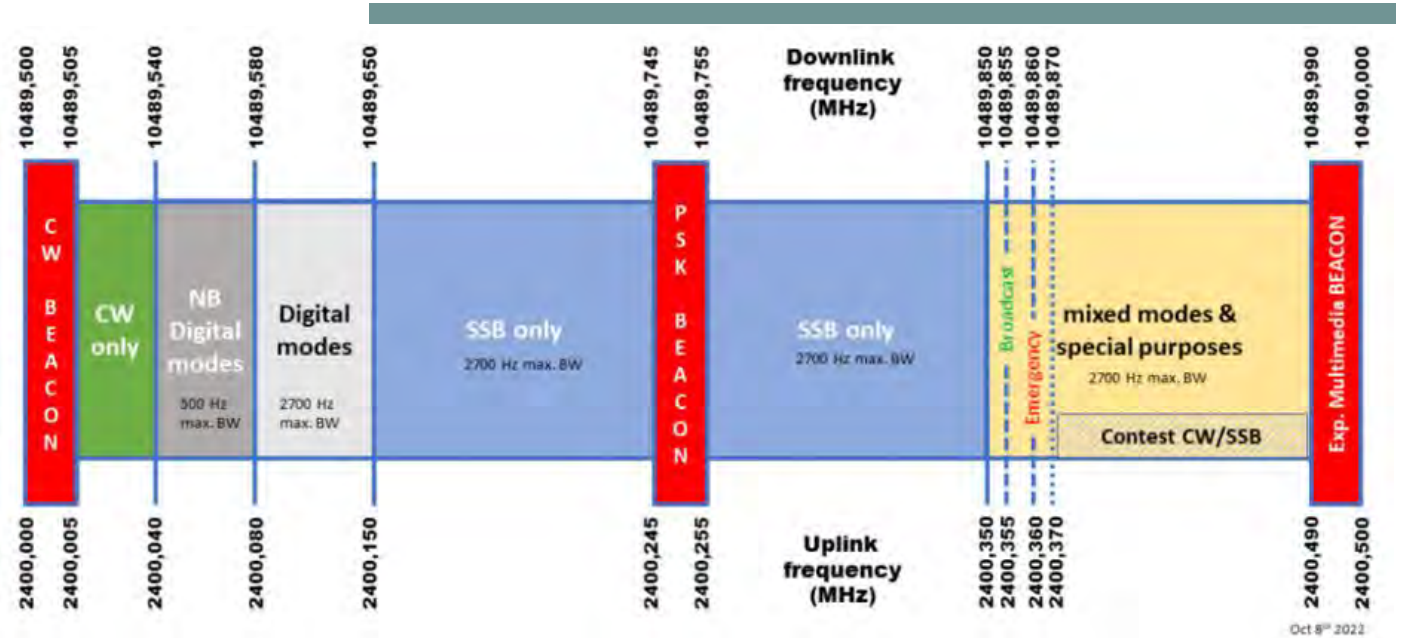

Figure 1. QO-100 Narrowband Transponder band plan. (Courtesy of AMSAT)

(QO-100 Ground Station from page 19)

it) via this amazing geostationary satellite.

My basic understanding after this conversation was that Es'hail QO-100 satellite consists of a 2,4 GHz / 10,4 GHz narrowband and broadband transponder, piggy-backed onto a Qatari television satellite in a geostationary orbit, positioned at 25,9° East over the equator, 35 000 km above the Democratic Republic of Congo. Its footprint covers from 70° North to 70° South and from 60° West to 90° East. The narrowband transponder is for CW, digital and SSB phone communications and the wideband for Digital Amateur Television. With the correct equipment, it is possible to contact a multitude of countries. Operating skill needs to be acquired, but as the saying goes, practice makes perfect.

Above, courtesy of AMSAT, is an illustration showing the layout of the narrowband (NB) transponder band plan.

There are several ways in which to construct a QO-100 narrowband ground station. This article assumes the constructor will be using a Pluto+ SDR as their designated transceiver and a POTY (Patch of the Year) 2,4 GHz, transmit antenna. Of course, other amazing equipment exists. For the enthusiast who already has a 2 m/70 cm/23 cm/10 m capable transceiver in use, a DX Patrol QO-100 Up Converter MK4 unit can take the place of the Pluto/Laptop and there will be no need to consider selling that treasured rig when downsizing the QTH.

3. QO-100 vs HF Comparison

Perhaps the best way to present what I learnt from my conversation with Henry is to tabulate the main points, whilst simultaneously comparing the immediate pros and cons with HF communications.

(Continued on page 22)

| QO-100 vs HF Radio Comparison Table | | | | |
|-------------------------------------|--------------|---------------------------------------|-------------------------|--|
| # | Description | QO-100 Transmissions | HF Transmissions | Pro / Con / Par |
| 1 | Mode | SSB, digital (PSK, FT8, etc.) CW | AM, SSB, digital and CW | Par – band sections also allocated for CW, digital and phone |
| 2 | Format | Full Duplex | Simplex / Cross band | Pro - Full duplex |
| 3 | Frequency | Uplink 2,4 GHz and down-link 10,4 GHz | 160 to 10 m | Pro – 500 kHz of QRM and QRN free bandwidth |
| 4 | Output power | Typically, less than 10 Watts | Up to 1 000 Watts | Pro – Reception always possible with just a few watts |

| | | | | |
|----|--------------------------------------|--|---|--|
| 5 | Propagation | Not reliant upon propagation conditions | Reliant upon propagation | Pro - Band permanently open. Never fades. |
| 6 | Coverage Area | 70° North to 70° South / Brazil to Thailand | All over the World | Con – with QO-100, the world is half your oyster |
| 7 | Cost | Approximately R12 000 to R20 000 (new equipment) | Approximately R8 000 to R20 000 (some second-hand equipment) | Par – Costs no more than setting up a professional HF station |
| 8 | Antenna size | Small – 60 cm to 1,2 m satellite dish | Large - Depends upon space available and band being used | Pro – A fraction of the size and price of a high gain HF antenna. |
| 9 | Electrical Interference | Rare – average noise level S1 | Common – average noise level S5. Many amateurs complain of S9 level noise. | Pro – non-existent |
| 10 | HOA Interference | Rare – looks much like a DSTV dish | Common – highly noticeable | Pro – HOA can hardly tell the difference between this and a DSTV dish. |
| 11 | Standard equipment required | Computer, Satellite dish, bracketry, LNB, DC injector, TX, POTY (Patch of the Year) / Helical TX antenna, low-loss feeder and SMA/ N-type connectors, 5, 12 and 24 v power supplies, mains lead, mounting cabinet, SMA or N-type male fly leads, 20 W/2,4 GHz amplifier and heatsink | TX, connectors, feeder, 12 volt power supply, antenna matching unit, antenna and mounting structure of choice. | Con – A little tricky to work with as the GHz band is less forgiving than its HF cousin. Not too difficult to master once you understand the fundamentals of GHz band propagation and attenuation. |
| 12 | Preferred Test gear | RF Power Meter (low power), Vector Network Analyser (VNA), Digital Multi-meter. | RF Power Meter (high power), Vector Network (VNA) or HF Antenna Analyser, Digital Multi-meter. | Par – similar costs involved |
| 12 | Software Required for phone contacts | SDR Console and associated Windows driver. Various apps for logging etc. | Not absolutely necessary unless remote access or other software such as Ham Radio Deluxe (HRD) or logging apps are advantageous | Par – free to download and no harder to set up than the menu settings in your current HF rig. |
| 13 | Popularity | Small scale following | Large scale following | Pro – band space is always available. |
| 14 | Contests and Awards | Yes | Yes | Par – primarily organised by the QO-100 DX Club, ARRL and permitted by AMSAT-DL. Regular contests include the monthly QO-100 DX Club Sprint, featuring SSB, CW, Data and SSTV |

(QO-100 Ground Station from page 20)

4. Station Planning

With the above points in mind, I launched my investigations into what equipment I would require, where I would obtain it, how much it would cost, where I would mount it and from where I would operate. I strongly recommend completing as much technical and logistical research as possible before commencing with any build activities.

As luck would have it, the rear of my house is almost entirely screened from the view of any neighbours. Conveniently situated behind the garage is a section of wall not only out of view from prying eyes but also with a clear view to the satellite. To be sure of this, I got out my trusty compass/inclinometer and confirmed line of sight (LoS).

With this confirmed, the next task was to identify the location of my future operating desk. This turned out to be the rear corner of my double garage. From here, I would mount my equipment cabinet on the wall and run a pair of low loss feeder cables up through a neatly drilled hole, to the soon to be LNB and POTY antenna positions. The proximity of my operating desk to my dish has facilitated the use of short coaxial feeder lengths. My installed lengths are only 7 m, including 1,5 m of slack in case of future adjustments.

For convenience, your dish can even be mounted at ground level, just as long as it can “see” the satellite.

5. System Overview

I then created an equipment block diagram, a copy of which is shown in Figure 3 below. I mapped out a system incorporating a Pluto+ SDR, RF



Figure 2. QO-100 dish Installation

Amplifiers, a Bullseye LNB for the 10 GHz downlink and a POTY antenna for the 2,4 GHz uplink. The POTY (Patch of the Year) antenna is a dual band antenna. For transmission it is LH circularly polarised and designed to resonate slightly above and below 2,4 GHz. For reception it incorporates a vertical linearly polarised 10,4 GHz antenna / waveguide which slides into the horn of the Bullseye LNB. Slotted into the front of the POTY antenna is a dielectric lens designed to focus the received signal into the POTY waveguide and hence

(Continued on page 23)

QO-100 Ground Station Block Diagram

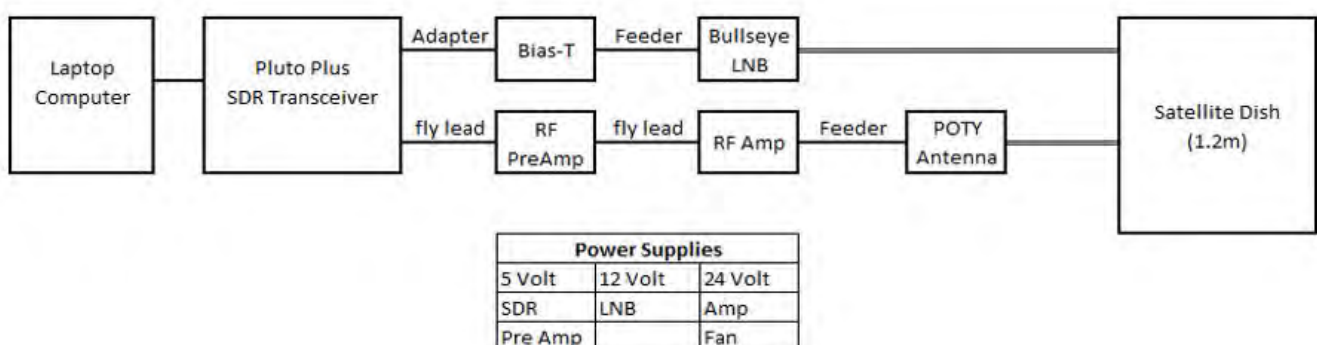

Figure 3. System Block Diagram

(QO-100 Ground Station from page 22)

through to the LNB antenna. One just needs to keep in mind that due to the combined elevation / azimuth of the satellite relative to one's fixed position on Earth, a certain degree of skew needs to be applied to the LNB by rotating it a degree or two within its mounting collar. This aligns the LNB with the exact angle of the incoming 10,4 GHz linear polarised signal. The above block diagram shows my proposed system layout. The diagram also shows which power supply is used for which module.

6. Equipment Selection

I would like to mention at this point that it is crucial to acquire reliable, stable products. For example, a small amount of LNB induced frequency drift can inflict a serious impact upon SSB reception, thereby requiring continual Receive Incremental Tuning (RIT) when detecting the fundamental downlink frequency of 10.4 GHz.

I should also mention the potential risk associated with the purchase of cheap Chinese pre-amplifiers, power amplifiers and DC injectors, etc. Unfortunately, I have had both a pre-amplifier and a linear amplifier pop for no apparent reasons. It

may have been because of an unwanted RF power surge, but unfortunately, I will never know. On the other hand, however, some people may never experience this issue. As a good friend of mine often says, "You pays your money and takes your choice". Consequently, my transmit RF amplification stages now come from a lab in Bulgaria, complete with gain adjustment and protection circuitry.

Next, I selected the remaining parts such as the accessories required to power the station as well as some basic test gear and placed an order with an online supplier.

With my order on its way, I quickly visited a hardware store and acquired a suitable mounting bracket for the dish. This was duly installed with strict focus placed upon correct positioning and orientation.

7. Build Process

I now drilled a hole through the garage wall, enabling my transmit and receive feeder cables to reach the POTY antenna and Bullseye LNB respectively.

For transmit I used LMR-400 cable and for

(Continued on page 24)



Figure 4. POTY 2,4 GHz TX Antenna



Figure 5: Bullseye & POTY installed

(QO-100 Ground Station from page 23)

receive I used military spec RG-6U. Both feeders exhibit very low loss to signals in the GHz ranges. RG-6U loss is roughly 5 – 6 dB per 100 feet at 1 GHz and LMR-400 typically 6,8 dB - 10.8 dB per 100 feet at the higher microwave frequencies (2,4 – 5,8 GHz).

It should be noted that although the QO-100 downlink sits in the 10 GHz range, optimum performance of the receive cable only needs to be around 739 MHz. This carries the down converted output frequency of the LNB and hence the signal fed into the Pluto+ receiver port.

Interestingly, the LNB signal is analogue in nature (USB) and can therefore be monitored with an Icom or AOR broadband receiver. This can be used to advantage when panning for the QO-100 beacon.

With the bracket in place and keeping safety in mind, I carefully hoisted the already assembled dish up onto the roof. Placing it over the mounting pole and manoeuvring it into place was relatively easy.

Prior to running my feeders and cable tying them into place, I attached my respective N and F type connectors and buzzed them through for DC continuity and/or potential shorts.

Next came the positioning and fastening of the LNB and POTY antenna. Having already assembled the POTY on my workbench, fastened it into the horn of the Bullseye LNB and sealed everything up, all I had to do was to screw it into place and join the connectors.

Whilst purchasing the mounting bracket, I also bought a wall mount box in which to install the SDR, power supplies, TX pre-amplifier and TX linear amplifier and heat sink. In a belt and braces

approach, added a small computer fan to provide forced air cooling.

I mapped out the location of all the equipment destined for installation within the 35 cm x 30 cm x 20 cm sized equipment cabinet and drilled the required mounting screw holes. Figure 6 has been provided to show the order in which all my construction activities were completed.

I should mention at this point, that some constructors prefer to mount a weatherproof equipment box outdoors, positioned close to their dish. This choice is usually implemented when the operating desk is some distance away, thereby keeping the RF feeders as short as possible.

In this configuration, power is run via an outdoor electrical feed and the SDR is connected to the distant computer via a POE (Power over Ethernet) LAN (Local Area Network) cable of multiple metres in length.

Please consider safety and electrical compliance if taking this route.

Because my feeders are only 7 m long, I decided to mount my equipment box onto the interior garage wall, adjacent to my operating desk. This enabled me to obtain power from a nearby AC mains socket, instead of running power outside as well as connect to the computer via a standard USB cable.

In my opinion, this is a safer and less expensive approach in terms of safety, equipment access, equipment performance and preventative maintenance. I recommend this approach when possible.

All equipment was duly installed with the exception of the Pluto+ SDR, which I first took to my study to configure along with the SDR Console software. I will not go into the details regarding how it needs to be set up, but if asked, I am happy to write a future article explaining what needs to be configured and how any trouble shooting can be carried out.

With the wall mounted box in place and the Pluto+ now in its designated position, I heated up my glue gun and neatly bonded a PVC conduit into a corner of the garage wall through which the feeders were then run.

With the antenna VSWR at 2.4 GHz tested, RX and TX RF connectors attached and tested,

| Task Description | Order of Completion |
|--|---------------------|
| Confirm dish position/orientation | 1 |
| Assemble Dish | 2 |
| Install Dish Mounting Bracket | 3 |
| Construct POTY | 4 |
| Join LNB and POTY | 5 |
| Install Dish | 6 |
| Install LNB/POTY | 7 |
| Drill hole in wall | 8 |
| Attach coaxial connectors at dish end | 9 |
| Run feeders and cable tie | 10 |
| Tape up connectors | 11 |
| Mount RF amp on heatsink | 12 |
| Position equipment in cabinet and mark up | 13 |
| Drill mounting holes | 14 |
| Fix equipment in place and wire up. | 15 |
| Install SDR Console on laptop | 16 |
| Install Pluto + Driver on laptop | 17 |
| Install Pluto + in cabinet. | 18 |
| Power up receive | 19 |
| Pan Dish and lock in place | 20 |
| Perform RX tests | 21 |
| Lock dish in place | 22 |
| Power up transmit | 23 |
| Perform TX Tests | 24 |
| Lock TX levels - do not overdrive Amplifiers | 25 |

Figure 6. Build Activity Sequence

(Continued on page 25)

(QO-100 Ground Station from page 24)

the system was initially powered up on receive only.

From my speakers came the welcome sound of white noise but unfortunately no QO-100 transmissions. This was to be expected though as it would have been a one in a million shot, had the dish already been pointing in exactly the right direction.

Figure 7 shows the final, enclosed unit. The voltage and current meter were added post construction upon advice from Henry. As there is no LED available on the final amplifier to indicate whether it is being keyed, a clever alternative is to install a DC power meter to show the supply voltage and how much current is being drawn. This is much like the meter on your valve HF rig that monitors how much grid or plate current is being drawn. The lifetime of your PA will be extended by ensuring the supply voltage and current consumption remain within the manufacturer's technical specifications.



Figure 7. Completed Station

8. Alignment & First Reception

Now, came the big moment. I.E. Would I be able to locate the satellite by myself or would I require some assistance? As it so happened, my planning paid off. Within a few minutes and only two trips up and down the ladder, I found the satellite with initial signals coming in at S3. The feeling of achievement at that exact moment was overwhelming. Somehow, I had managed to build a working – albeit receiving - satellite station. Hello again to DX! All that I needed to do now was optimise my dish azimuth and elevation settings with a view to securing the strongest possible signal readings.

At this point I seconded my wife into action and between me on the roof and she at the computer screen, we jointly panned the dish into place and locked in the best reception. By now the peak signals were appearing at the 59+10 mark. The TX path was then powered up, calibration and duplex transmission tests performed and the rest as they say, is history.

9. Link Budget Explanation

With an adequate and balanced link budget in place, clear and reliable communications can take place between the Earth and QO-100. This should be carefully investigated during your design phase as it will impact both your transmitted and received signal levels.

The narrow band system emits a typical output EIRP of 52 – 57 dBW. It operates as a linear transponder, meaning it does not have a single fixed output power, but rather amplifies the signals it receives on 2,4 GHz, which are then repeated 35 000 km back to Earth where they are received via a 0,8 – 1,2 m dish with a gain of approximately 30 - 40 dBi.

The below link budget tables provide typical uplink and downlink pathloss and system gain values with a view to explaining how it is that 59+10 signal reports are actually possible with such low-level RF inputs. The QO-100 DL operates in the 3cm band. At this wavelength, losses need to be kept to an absolute minimum. Good quality cables and connectors are a must. Therefore, be especially wary of cheap SMA or N-Type connectors and adapters.

(Continued on page 26)

(QO-100 Ground Station from page 25)

By comparison to HF, I find the QO-100 link budget scenario quite fascinating. For example, look at the free space pathloss. For years I operated on the HF bands with far less propagation loss, often with a 400- or 1 000-Watt linear amplifier and still somehow struggled to get a 59-signal report from the UK or the USA.

| Uplink (Ground → Satellite) | | |
|-------------------------------|---------------------------|---------------------------------|
| Parameter | Value | Notes |
| TX Power (at Pluto) | 0 dBm (1 mW) | Typical SDR output |
| Driver amplifier gain | +12 dB | Pre-amp stage |
| Final amplifier gain | +25 dB | ~20 W class PA |
| Cable & connector losses | -8 dB | LMR-400 + connectors |
| Dish antenna gain | +25 dBi | ~80 – 100 cm dish @ 2,4 GHz |
| EIRP (uplink) | ≈ +54 dBm (≈ 250 – 300 W) | Key assumption |
| Free space path loss | -193 dB | 2,4 GHz @ 35,786 km |
| Satellite RX antenna gain | +30 dBi (est.) | Spot beam gain |
| Power at satellite RX | ≈ -109 dBm | Within linear transponder range |
| Downlink (Satellite → Ground) | | |
| Parameter | Value | Notes |
| Satellite transponder EIRP | +52 to +57 dBW | (≈ 82 – 87 dBm EIRP) |
| Free space path loss | -206 dB | 10,489 GHz @ GEO distance |
| Ground station dish gain | +38 to +42 dBi | 80 – 120 cm dish |
| Feed / pointing losses | -1 to -2 dB | Practical inefficiencies |
| LNB noise figure | ~0,5 – 1 dB NF | Very important |
| Received signal level | ≈ -75 to -85 dBm | Typical observed |
| SDR input frequency | ~739 MHz | After LNB down-conversion |

10. QO-100 Technical Specifications

The below table provides some technical specifications for the QO-100 satellite:

| Parameter | Specification |
|---------------------------------|--|
| Satellite Name | Es'hail-2 |
| Amateur Designation | QO-100 |
| Orbital Position | 25,9° East (Geostationary Orbit) |
| Coverage Area | Europe, Africa, Middle East, Brazil (eastern), parts of Asia |
| Orbit Type | Geostationary (GEO) |
| Transponder Type | Linear bent-pipe transponders |
| Narrowband Downlink EIRP | Approx 52 – 57 dBW (158 – 501 Watts) |
| Narrowband Bandwidth | ≈ 500 kHz total including beacons |
| Wideband Bandwidth | ≈ Approx 8 MHz |
| Modulation Modes (NB) | SSB (USB), CW, Digital modes |
| Modulation Modes (WB) | DATV (Digital Amateur Television) |
| Beacon Frequency (NB) | 10 489.550 MHz |
| Beacon Frequency (WB) | 10 491.000 MHz |
| Approx. Payload RF Output Power | ≈ 2 – 3 W per transponder (estimated) |
| Satellite Operator | Es'hailSat (Amateur payload by AMSAT-DL) |
| Launch Date | 15 November 2018 |
| Launch Vehicle | Falcon 9 |

11. Conclusion

(Continued on page 27)

(QO-100 Ground Station from page 26)

Despite increased modern day constraints, it is possible to operate a cutting-edge DX station from a smaller property. For the same cost as a medium-priced HF transceiver, a satellite system can be constructed and commissioned in the domestic workshop with no requirement for sophisticated tooling other than a soldering iron and a technician's toolbox. I hope you will take the leap as I did and join me in a world of DX where the band is always open and there are plenty of countries with which to make contact.

Should you be unsure whether to take the plunge, kindly note it is possible to listen to QO-100 via the Goonhilly Web SDR site. I strongly recommend doing so as it will provide an opportunity to assess signal levels, audio quality, band usage, typical conversations and group nets. Having experienced this, you will soon know whether the bug has bitten. The link to this web SDR site is provided below amongst the list of other useful links and interesting videos to watch.

If you have any questions, I can be reached at: turner.a.kevin@gmail.com Please feel free to make

contact and I'll be only too pleased to assist.

Useful links

- ◆ <https://amsat-uk.org/satellites/geo/eshail-2/>
- ◆ <https://satellitemap.space/>
- ◆ <https://eshail.batc.org.uk/nb/>
- ◆ <https://qo100dx.club/>
- ◆ <https://www.facebook.com/groups/391111521731871/>
- ◆ <https://qradiolink.org/internet-over-QO100-amateur-radio-satellite.html>
- ◆ [QO-100 Presentation](#)

Interesting Videos

- ◆ <https://www.youtube.com/watch?v=6Yxi6nN6dOY>
- ◆ <https://www.youtube.com/watch?v=Xvrt7aans5c>

Acknowledgements and Thanks

Henry, ZS6MC – Technical advice and proof reading
 Hristiyan, LZ5HP – Technical advice
 Richard, F4WCD – Proof reading and publication advice

AMSAT-DL to Highlight QO-100 at Friedrichshafen

ANS-137 AMSAT News Service Bulletins

As part of the "HAM RADIO 2026" event at Friedrichshafen, Germany from 26 to 28 June, AMSAT-Deutschland e. V. (AMSAT-DL) cordially invites all QO-100 users and amateur radio satellite enthusiasts to an open community workshop.

Building on the experiences with Qatar OSCAR 100 (QO-100) and current activities in the future geosynchronous Earth orbit (GEO) environment, the event invites amateurs to discuss together with the community what a future geostationary amateur radio payload could look like. The aim of the workshop is to gather ideas, requirements and perspectives from the user community and place them in a common context.

As a basis for the discussion, AMSAT-DL will present 2 - 3 concrete mission and payload concepts that reflect different development directions and are deliberately put up for open discussion:

1. "Enhanced QO 100+" (basic) An evolutionary approach that builds on the success of the QO 100:

classic bent-pipe narrowband and wideband transponders, an advanced beacon architecture, multi-band downlinks and additional functions such as text and image transmission, e.g. for emergency and disaster communication, Internet of Things, etc.

2. Digital Innovation Lab (extended) A more experimentally oriented concept with extensive digital signal processing on board. The focus is on flexible, software-defined payload architectures (SDR), regenerative processing and a "digital playground" for new modulation and access methods and user experiments. But with the risk of being very software-heavy.

3. "High Frequency Pathfinder" (optional) An explorative approach with beacons and experiments in very high frequency ranges (mm Wave), supplemented by new antenna concepts, propagation and environmental measurements as well as earth and space imaging.

(Continued on page 28)

(QO-100 Ground Station from page 27)

Open workshop

The workshop is designed to be explicitly open.

These concepts are not intended as ready-made solutions, but as a basis for discussion. The aim is to evaluate together with the participants which approaches are particularly interesting, sensible and sustainable for the amateur radio satellite community. Which aspects should be pursued further or in greater depth, but also the risks and dependencies should be addressed.

Both experienced satellite radio operators and anyone interested in the future development of amateur radio satellites, new technical concepts and possible applications are invited to attend.

Thematic focus:

- ◆ Experiences and lessons learned from the operation of QO-100
- ◆ User requirements and expectations for future GEO amateur radio payloads
- ◆ Discussion of the 2 - 3 future GEO concepts

presented

- ◆ Possible technical development directions and areas for experimentation
- ◆ Role of the amateur radio community in future missions

The workshop thrives on participation, discussion and the exchange of ideas – it is not a frontal lecture, but an interactive format with an open end.

Organizational data

- ◆ Event: futureGEO Community Workshop
- ◆ Date: Saturday, 27 June 2026
- ◆ Start: 16:00
- ◆ Duration: open end
- ◆ Venue: HAM RADIO 2026, Friedrichshafen
- ◆ Room: (to be announced and can be found in the lecture programme)

Registration is not necessary – just come along and bring your ideas, questions and experiences!

[ANS thanks AMSAT-DL for the above information]

Launching Satellites With Zero Emissions

ANS-137 AMSAT News Service Bulletins

Most rockets burn thousands of litres of fuel before they even clear the launch pad. SpinLaunch aims to skip that phase. Using a vacuum sealed centrifuge at Spaceport America, the California based company spins payloads to 8 000 kilometres per hour before releasing them skyward. A small rocket motor handles only the final orbital insertion, bypassing the most fuel intensive part of

the journey.

By September 2022, SpinLaunch completed ten successful suborbital tests, carrying hardware for NASA, Airbus and Cornell University. While the flights themselves are less intense, the company's lab qualification in Long Beach proved that satellite components could survive 10 000 G of centrifugal force, the exact environment required for a kinetic launch. NASA's data confirmed the system is compatible with standard satellite hardware, clearing the first major hurdle for the technology.

A conventional rocket's fuel requirement increases exponentially with its payload. By providing 70% of the initial velocity on the ground, SpinLaunch's kinetic approach drastically reduces propellant needs. This puts projected launch costs between \$1 250 and \$2 500 per kilogram, less

(Continued on page 29)



The spinlaunch Orbital Accelerator will accelerate a launch vehicle containing satellites up to 8 000 kph using a rotating carbon fibre arm within a 100-metre diameter steel vacuum chamber. (Image credit: <https://www.spinlaunch.com/>)

(Launching Satellites from page 28)

than half the price point of a SpaceX Falcon 9. Beyond cost, the system produces zero combustion emissions during the acceleration phase and minimizes orbital debris by eliminating expendable booster stages.

The transition from suborbital prototypes to a full orbital accelerator remains the project's greatest challenge. At orbital speeds, atmospheric drag becomes a violent engineering obstacle. While suborbital tests validated the physics at a smaller

scale, the orbital class centrifuge remains in an exploratory phase as of May 2026. The question is not whether the centrifuge can spin; it is whether a vehicle can survive the transition from a vacuum chamber to the thick atmosphere at hypersonic speeds.

[ANS thanks Futura for the above information. Read the full article at <https://www.futura-sciences.com/en/no-more-rockets-the-wild-new-tech-launching-satellites-with-zero-emissions-31307/>.]

The Pretoria ARC May RAE – A Signal of Renewal

Martie Venter, ZS6MV

For years, PARC had not hosted formal training. Now, with a revitalised team, a new clubhouse and the distinction of being a Registered SARL Exam Centre, the stage was set for something significant — an era of growth and fresh signals on the bands.

16 May could not come soon enough for the Pretoria Amateur Radio Club's RAE Team of Hendri Ehlers, ZS6HFE; Pierre Holtzhausen, ZS6PJH; Johan Lehmann, ZS6JPL; Lous de Wet, ZS6SK; Almero du Pisani, ZS6LDP; Vernon Fryer, ZS6AIG and Martie Venter, ZS6MV.

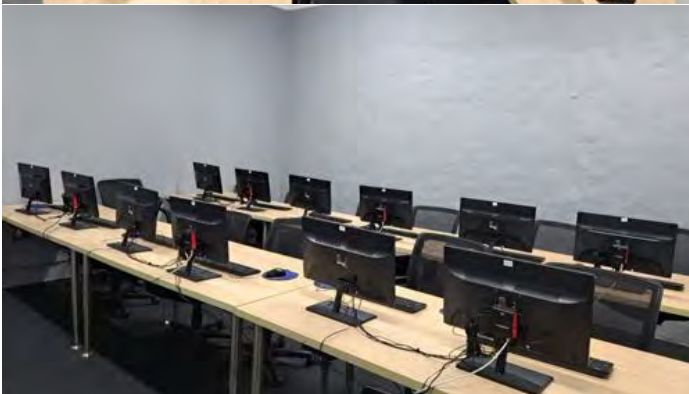
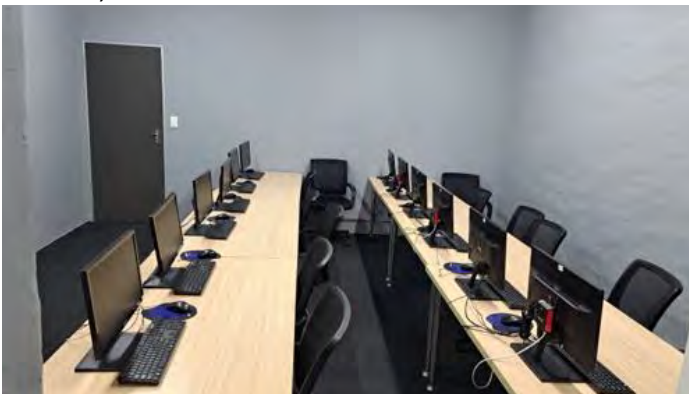

Though the whole team could not be present, the airwaves carried their encouragement.

Messages flowed in from club members and amateur-friends, each one like a steady signal breaking through the noise. Their words reminded the candidates that amateur radio is never a

(Continued on page 30)

(Pretoria ARC May RAE from page 29)

solitary pursuit — it is a fraternity where voices echo across distance and support is always just a call away.



That chorus of encouragement added warmth to the day, reinforcing that PARC's revival is not only about exams and papers, but about community, camaraderie and the shared joy of keeping the bands alive

By just after 08:00, aspiring amateurs began arriving, greeted by the warm aroma of coffee and toasted sandwiches, delivered to the exam centre from the restaurant that has embraced "radio people" with open arms (proof that amateur radio can flavour more than just the airwaves).



The atmosphere was alive, buzzing like a freshly -minted rig breaking into the bands — crisp, eager and humming with promise. Coffee cups were refilled, muffins nervously nibbled and conversations carried the cadence of CQ calls waiting to be answered.

Once the invigilator announced it was time to move to the exam room, the atmosphere shifted — it felt like tuning to a different band. The team got down to business: rules read, registers signed, exam papers handed out. The countdown had begun.

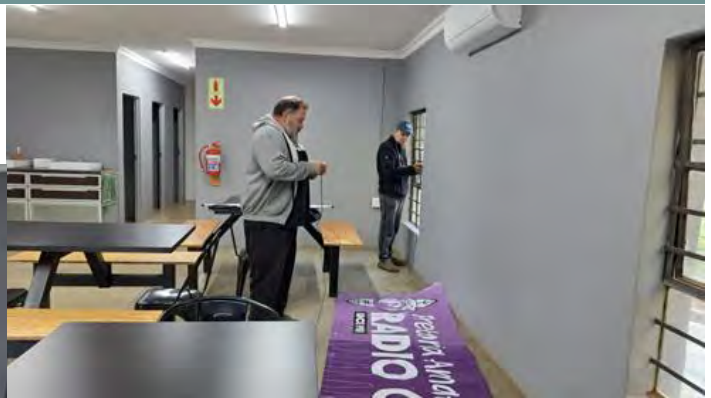

As the pages of the exam turned, aspiring amateurs found their rhythm and confidence. A knowing nod here, a quiet smile there—signals of determination breaking through the static. The silence was charged, not unlike a band waiting for the first CQ to roll across the ether.

(Continued on page 31)



(Pretoria ARC May RAE from page 30)

Every tick of the clock carried the weight of preparation, yet the room resonated with calm focus. This was more than just an exam; it was the threshold to becoming part of the amateur radio family, where discipline meets passion and every signal carries a story.

Guy, ZS6GUY, President of the SARL, was there to greet the aspiring amateurs as they stepped out of the exam room. He waited patiently in the morning sun, a steady presence as the group finished. Handshakes and chatter filled the air – the

RAE team smiling at each other, knowing that we were part of something great.

What began as nervous anticipation quickly shifted—like static fading into a clear signal. Relief broke through, jokes sparked across the group and a shared sense of accomplishment settled in. The exam was behind them and the horizon ahead was filled with the promise of new voices on the bands.

This was more than just a test; it was a rite of passage. Each smile and laugh carried the resonance of future QSOs, friendships and the enduring spirit of amateur radio.



(Satellite Shorts from All Over from page 18)

satellites and disrupt communications, navigation and surveillance systems worldwide. Previous government assessments suggested portions of low Earth orbit could become unusable for up to a year following such an event. More than 60 companies participated in the exercise, along with allied

partners from Australia, Canada, New Zealand and the United Kingdom. Space Command plans additional Apollo Insight exercises later this year focused on orbital manoeuvre warfare and other evolving space threats. (ANS thanks Ars Technica for the above information).

What happened on Friday 1 May at the Willows?

Thanks to Kevern, ZR2BK and Eugenie Burger for the photos





Beverley, XYL of Dave, ZS2DH; Odette, ZS2OD and Eugenie, XYL of Kevern, ZR2BK

Beverley and Odette with some of the sponsored refreshments



Brian, ZS6YZ (red jacket); Woody, ZS3WL explaining something; Dave, ZS2DH; Jan, ZS4JAN; Carina, XYL of Dennis, ZS4BS and Anette, ZR6D







Brian, ZS6YZ and Gary, ZS6YI
Jan, ZS4JAN with the Lotriet family - Esmarie, ZS3EL; Peet, ZS3PL; Petrus, ZU3PL and his two brothers.



Rulhof's Granny; Rulhof, ZS4RM; Theunis, ZS2EC and Andrew, ZS2G
Donovan, ZS2DL and Nico, ZS6QL with Yolanda, friend of Guy, ZS6Guy



Beverley, ZR6BVT and Phillip, ZS6PVT (yes, he could have combed his hair!)

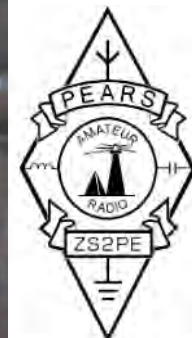





Beverley and Dave, ZS2DH with Jan, ZS4JAN, maybe Rassie, ZS1YT and Corri, ZS6CDB and a lo of liquid refreshments!

Magda, ZS6MMS and Lucas, ZS6ACT and





Mini-Circuits

DC TO MM WAVE

7,500+ products
across 27 product lines

400+ new products
every year

Minimal end-of-life
and low returns

 RF DESIGN



www.rfdesign.co.za



sales@rfdesign.co.za

 ez samples
Try before you buy

The South African Maritime Mobile Weather Net

The Maritime Net is on the air daily at 06:35 UTC [08:35 CAT] and 11:35 UTC [13:35 CAT] on 7,120 MHz LSB and 14,316 MHz USB.

The 06:35 UTC and 11:30 UTC transmissions are for High Seas METAREA 7 which covers from Ascension Island down to Madagascar East and Marion Forties on 14,316 USB.

The coastal weather and general sails are on 7,120 MHz LSB after the main weather broadcast.

The team is Peter, ZS1CH; Marjoke, ZS5V; Woody, ZS3WL and Johan, ZS6WZ.

The IARU Intruder Watch Service (formerly the IARU Monitoring System or IARUMS) is a worldwide service authorised by the IARU Administrative Council. It is served by dedicated volunteers.

A monthly IWS Newsletter is published and can be downloaded from <https://www.iaru-r1.org/spectrum/monitoring-system/iarums-r1-newsletters/>

The Mast...

Patsy Kruger, ZS2PTY

first published in QSX-PE May 2026

Where do I begin...? 2 December 2025 was a beautiful sunny morning and I had just moved from PE to a farm in Alexandria about a month earlier. My duties as occasional news reader together with an upcoming Hamnet event had prompted me to get my 2 m up and running so that I can be prepared for whatever amateur related event comes my way. Being an expert at procrastination I was awfully chuffed at myself for being such a pro-active YL. Well, after spending most of the morning climbing over a mountain of boxes I finally made it to the corner of the room where the mast was situated/ dumped/stored make your pick. This particular telescopic mast of which I am the very proud owner, was originally "sponsored" by Escom via via via to the last owner who in turned agreed to swop it for a bottle of whiskey. Bargain indeed.

Now that we all know how I came about the mast we can move on to the very important "how not to" part from my story. The weather by now was less pleasant and when you only weigh 49 kg, windy conditions are at best very unfavourable!

Known to run barefoot where angels fear to tread, I did not let this stop me in any way. I was determined to get my rig up and running. Installed the antenna, found a suitable pole, secured the mast with strong cable ties and proceeded to extend the mast. I used a sharp nose plier to secure the button lock of each layer working with my arms slightly raised above my head while the wind tried its best to displace me as far as possible. About 3 layers in, my not so 'fris' arms were pretty tired of this mast work and simultaneously hanging on while my chicken legs were blowing about.

Then, in a moment of weakness, actually utter stupidity, I let the mast collapse... sucking in the fleshy part of my palm on the thumb side! The pain was incredible; my life flashed before my eyes while my pride took a serious beating as I realized – this was bad and as far as boo-boos goes about a number 1. Not only was I standing out of reach of any form of structure to support me, but my free arm was also too tired to extend the mast and my hand was solidly stuck! To add insult to injury I also



lived alone and for a brief second the thought crossed my mind that I might actually be a piece of biltong by the time someone most probably an affirmative shopper discovered me.

Panic mode over, I considered my options - extend the mast somehow/pull my hand out and sacrifice whatever stays behind or chew off my wrist. Last mentioned not being such a good option when you have two huge blood thirsty Anatolian Shepherds hanging around. I thus opted for a combination of the first two choices.

Low and behold fellow amateurs, I mustered my final strength and managed to lift the pole ever so slightly while I yanked with all my might. Overcome by nausea, pain and a tremendous sense of relief, I fought back the tears and inspected the damage... not a single drop of blood was shed during this whole traumatizing event! Besides pain and a very hard lump I had no evidence of my so-called life-threatening incident. O well, like the words of a popular song from days gone by... "Big girls don't cry." Tempted to call it a day my

(Continued on page 40)

(The Mast from page 39)

stubbornness got the better of me and I decided to complete the mission.

After a well-deserved rest and the wind being a bit more merciful, I had the mast up! My chest was bursting with pride, the anticipation unreal. I had done it all... Antenna, Mast, Solar panel, Battery, Radio... ZS2PTY calling CQ! Amateurs, I kid you not... my eager ears were met with deadly silence! Nothing, nada, morsdood!

Troubleshooting 101 done, mast down, cable check, mast up AGAIN and still nothing! I reached



The only tail I got when keying the mike.....



out via WhatsApp, natuurlijk, to my trusty friend Chris, ZS2AAW who came to the conclusion that NOPE I'm not able to get into my nearest repeater. O well, that was a darn painful T-Shirt to obtain.

Sadly the mast and I are not on good terms at the moment and it will remain in a lonely dark little corner until I get myself mobile again which I hope will be soon. My next adventure or possible disaster will be when I attempt to get my Icom IC 730 up and running.

Until then 73 and 88!

You are invited to join the Pretoria Amateur Radio Club for their next flea market and boot sale on Saturday 6 June 2026, at their new Clubhouse at 16 Catherine Street, Shere, Pretoria East.

Come and enjoy socializing with fellow amateurs and friends. Other Amateur Radio Clubs are also welcome to come and sell amateur related equipment and to market their Clubs.

Bring the whole family. There are Padel courts, a restaurant with a special HAM menu and playgrounds for the grandchildren.

Starting time is 09:00 for sellers and 10:00 for

buyers. To book a stand and table, contact Almero ZS6LDP, on 083 938 8955 or send an e-mail to almerodps@gmail.com. See you on Saturday 6 June at our Flea Market and boot sale in Pretoria.



Senator Ted Cruz Praises Amateur Radio Operators for Emergency Preparedness

The ARRL Letter for 28 May 2026



Senator Ted Cruz, [in a strong pre-Memorial Day message](#) publicly highlighted the critical role that Amateur Radio Service volunteers play during disasters, praising and thanking ham radio operators who provide essential communications when storms and emergencies knock out power and cellular networks and communities are cut off. Sen. Cruz observed that in these emergencies it is ham radio operators who step forward, bringing with them the tools, expertise and the commitment to reconnect people when it matters most. He noted this dedication was clearly demonstrated in 2017 when Hurricane Harvey's catastrophic flooding devastated communities across Texas and that it was demonstrated again more recently in the horrific Camp Mystic floods. He emphasized that as the Nation prepares for yet another summer storm season, ham radio's role remains just as vital as ever.

Stating that while future emergencies will come, Sen. Cruz pointed out that so would Amateur Radio — ready to respond, ready to serve and to make a difference. He ended his statements, thanking ham radio for its courage and commitment, noting that Amateur Radio's work strengthens our communities.

Senator Cruz is Chairman of the Senate Committee on Commerce, Science and

Transportation. His comments align with the ARRL's ongoing efforts to strengthen and protect Amateur Radio's role in emergency preparedness and public service communications.

His comments also reflect growing Congressional recognition of the value Amateur Radio Operators bring to communities across the country. ARRL continues to advocate for legislation that protects and strengthens Amateur Radio's role in emergency preparedness and public service communications.

The ARRL's nationwide grassroots campaign supporting the bipartisan [Amateur Radio Emergency Preparedness Act](#) has generated more than 155 000 letters to members of Congress in support of H.R. 1094 and S. 459. The legislation seeks to ensure that Amateur Radio Operators can install and maintain effective outdoor antennas at residences where private land-use restrictions might otherwise prohibit them, helping communities maintain resilient emergency communications capabilities during disasters.

ARRL Legislative Committee Chairman and West Gulf Division Director John Robert Stratton, N5AUS, said the continued outreach effort has required "long hours on the ground and an uncountable number of personal meetings with Senators, Representatives and their staffs" to raise

(Continued on page 42)

(Emergency Preparedness from page 41)

awareness of the importance of Amateur Radio to our country.

“The most recent proof that those efforts have and are, increasing Congressional support for Amateur Radio is evidenced by the decision of Chairman Cruz to publicly share his personal views on the value and importance of Amateur Radio to

the Nation,” Stratton said.

The ARRL encourages Amateur Radio Operators to participate in our letter writing campaign, located at www.arrrl.org/HOA, in support of the Amateur Radio Emergency Preparedness Act and to share information about the public service role Amateur Radio plays in communities nationwide.

Ywer laat amateurradio leef

LIENTJIE MENTZ

'n Matriekleerder van die Hoërskool Sentraal het Saterdag 2 Mei 'n eerbewys van die Suid-Afrikaanse Radioliga (SARL) ontvang vir sy bydrae tot amateurradio.

Rulhof van der Merwe is op die SARL se nasionale konvensie en jaarvergadering, wat van 1 tot 3 Mei in Gqeberha plaasgevind het, met die SARL se Jong Amateur-uitnemendheidseerbewys vereer.

Hy het in Mei 2022, toe hy 13 jaar oud was, die amateurradio-eksamen suksesvol afgelê en sy roepsein ZU4R verwerf. Daarna het hy die uitdaging gepak om sy ZS-roepsein te bekom. Die roepsein ZS4RM is aan hom toegeken twee dae voor sy 15de verjaardag.

Rulhof het 'n suksesvolle amateurradionetwerk in die Suid-Kaap begin om plaaslik, maar ook wêreldwyd, te kommunikeer met 'n klein tweerigting-radio.

Hy het ook 'n Echolink-netwerk in Bloemfontein vir plaaslike radio-amateurs begin.

Hy wil graag nuusbuletins, amateurradio-gesprekke en die uitsaai van interessante



Nico van Rensburg (ZS6QL), president van die Suid-Afrikaanse Amateurradioliga (links) oorhandig die eerbewys aan Bloemfontelner Rulhof van der Merwe (ZS4RM). FOTO: Verskaf

gebeurtenisse oor dele van die land en wêreldwyd uitsaai.

Die eerbewys is aan Rulhof toegeken vir sy aktiwiteite om die stokperdjie te bevorder. Ook omdat hy saam met die Bloemfontein-amateur-radio-

klub Voortrekkers gehelp het om hul kommunikasie-kentekens te verwerf en om die All-Star- draagbare node met Echolink in Bloemfontein op die lug te kry. Hy neem ook gereeld aan kompetisies deel.

What Causes Lightning? The Answer Keeps Getting More Interesting

Charlie Wood

<https://www.quantamagazine.org/what-causes-lightning-the-answer-keeps-getting-more-interesting-20260506/> and the ARRL Contest Update for 13 May 2026

Armed with a slew of new instruments, physicists are closing in on one of nature's oldest mysteries — and find that storm clouds are seething with violent and unexpected phenomena.

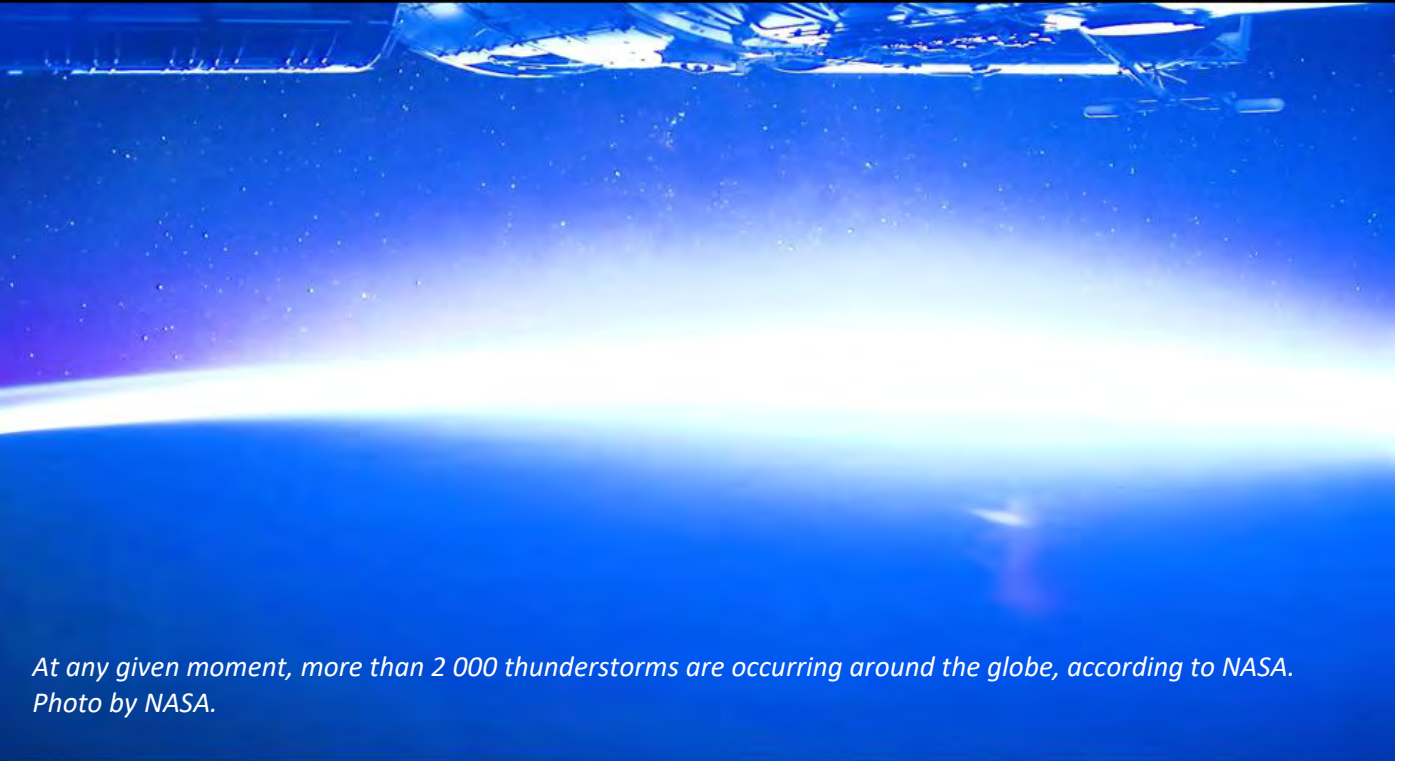

*At any given moment, more than 2 000 thunderstorms are occurring around the globe, according to NASA.
Photo by NASA.*

Before he changed the way we understand lightning on Earth, Joseph Dwyer studied the weather in more cosmic settings. Using the sensors on [NASA's Wind satellite](#), orbiting a million miles away, he watched flares shoot out from the sun and analysed the particles that stream from the sun's surface. But when he relocated to Florida around the turn of the millennium, Dwyer felt ready for something new — something he and his students could investigate on their own. It did not take long before the tropical weather delivered a suitable mystery outside his office window. "It was like boom, boom, boom outside," Dwyer said. "I looked into it and realized lightning was an *Joseph Dwyer pioneered lightning research by turning instruments designed to study violent cosmic events toward thunderstorms.*



Courtesy of Joseph Dwyer

unsolved problem."

Thunderstorms have captivated humanity for millennia and yet their inner workings remain deeply mysterious. Storm clouds are opaque. They are dangerous to approach. And they are too big to fit in a lab. Inquisitive researchers have been sending kites, balloons and rockets up into them for nearly three centuries and they have learned a lot. But every time lightning lovers get closer to the action, they discover major gaps in their understanding. For the past 50 years, researchers have focused on one particular gap - How does the jagged channel of white-hot air we call a lightning bolt get started?

Recently, the field has experienced a sort of renaissance as researchers, many of them astrophysics refugees like Dwyer, have devised new ways to pierce the clouds. They have taken a slew of instruments built to study violent cosmic events and trained them on the brutality of terrestrial

(Continued on page 44)

(What Causes Lightning from page 43)

thunderstorms. They have seen lightning shooting out X-rays as it zigs and zags, spotted flickering glows of gamma rays coming from thunderclouds and, very recently, detected hints of bolts traveling in unexpected directions.

No one has put all the pieces together, but a new understanding of lightning is taking shape. The fearsome flashes look less and less like the supersize electric sparks that physicists once imagined them to be. While electricity plays a central role, lightning bolts are formed and shaped by the whole physics canon — from cosmic blasts to particle physics. In particular, triggering a bolt seems to require extreme events more typically associated with supernovas, black holes and particle colliders than with fluffy clouds.

“There is a growing consensus in the field that high-energy processes play a critical role in lightning initiation,” said Caitano da Silva, an atmospheric physicist at New Mexico Tech. “It is an exciting time to be in this field.”

Trigger Point

When lightning bolts split the sky, the ancient Greeks, Scandinavians and Hindus saw flashes of divine warfare. And when thunderclaps rattled their chests, the Chinese felt a deity punishing wrongdoers. Today, the power of thunderstorms still leaves people awestruck.

“I grew up watching these large cold fronts coming in with a lot of lightning” in Brazil, da Silva said. “I grew terrified of it.”

With fear comes fascination. Yet despite centuries of exploration, fascinated physicists like da Silva are still asking the same question that the ancients did - How does lightning begin?

For a time, researchers thought they had an answer. As physicists demystified electricity in the 18th and 19th centuries, they learned how to make sizable sparks on command: pile up electric charge on one metal ball, bring a second nearby and a spark leaps between them. When researchers eventually worked out the structure of matter, they understood why. The separated charges generate an electric field between the balls. When the electric field reaches a critical strength, roughly 3 million volts per metre, the air starts to come undone. The field flings loose electrons into

neighbouring atoms, where they knock more electrons loose. Like snow on a steep mountain slope, the electrons “avalanche,” heating up the air until it glows.

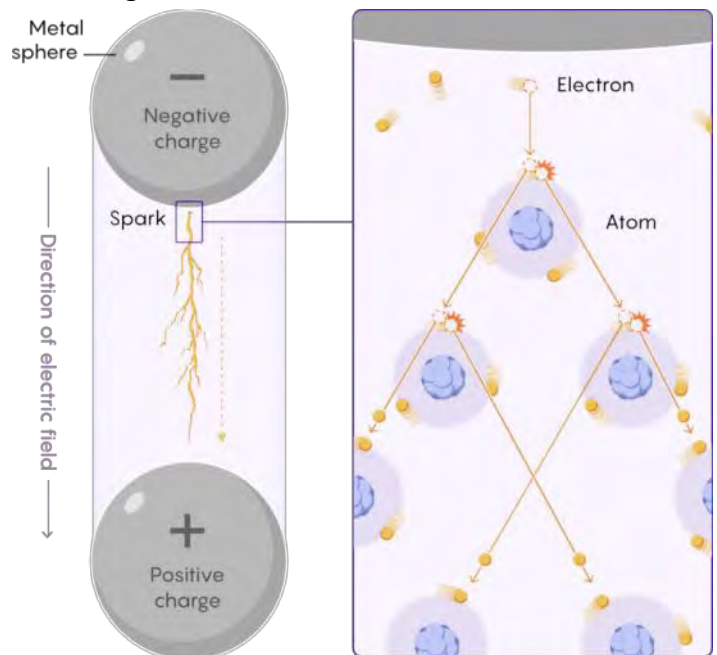

Mark Belan/Quanta Magazine

Benjamin Franklin linked sparks in the lab with lightning in the sky in his famous kite-flying experiment in 1752. And for the next 200 years, investigators believed that what happened in storm clouds was the same as what happened between their metallic spheres, just on a larger scale. The mystery of lightning seemed solved.

But when physicists graduated from kites to rockets and truck-size weather balloons in the mid-20th century, they found a problem. Clouds do have electric fields; tiny ice crystals rub against each other like socks against a carpet and crystals with extra electrons tend to pile up at the bottom of the clouds. But these fields are weak. Typical thunderstorms have just a tenth the electric juice needed to spark and the strongest fields ever measured reach just a third of the critical intensity. Yet according to [NASA satellites](#) there are more than 2 000 thunderstorms across the globe at any given moment — an observation as puzzling as avalanches thundering down bunny slopes.

“You have to increase the electric field all the way above the conventional breakdown threshold,” said Michael Stock, a researcher at the Cooperative Institute for Severe and High-Impact Weather Research and Operations at the University

(Continued on page 45)

(What Causes Lightning from page 44)

of Oklahoma. "But that doesn't seem to happen in nature."

A visible bolt means the air has broken down into a mess of hot, charged subatomic debris. So, either something has supercharged the electric field, pushing it past the critical threshold, or some other process must break down the air molecules. The question is - what?

One clue comes again from Franklin. He observed that sharp tips are more likely to start or receive a spark. Physicists now understand that this happens because pointed conductors enhance the nearby electric field. In the 1960s and 1970s, physicists in Florida and France started intentionally setting off lightning bolts by firing small rockets with sharp points into storm clouds. A wire would unspool behind the rocket and guide the bolt to the ground.

Most storm clouds do not have rocket-mounted darts to help them spark, but they do have ice crystals, some of which can exceed the size of a pencil eraser. These ice chunks, which are also conductors, can stretch into shards. Physicists estimated that sufficiently lengthy ice shards could boost the field strength by a factor of 10 or more and that a number of these so-called hydrometeors acting together could do even better. Once again, the mystery seemed solved.

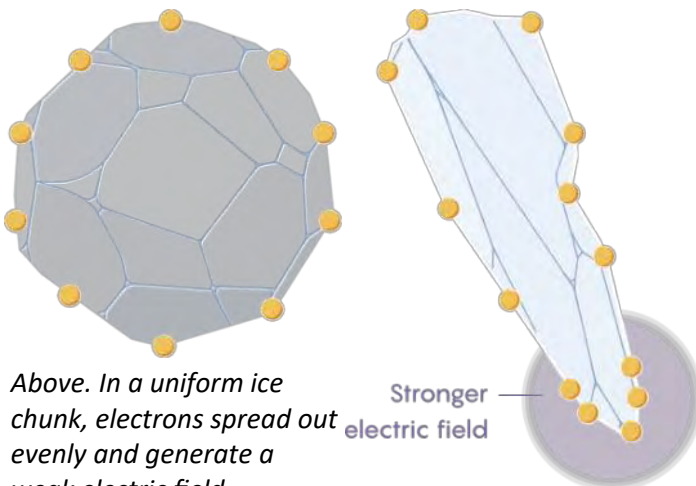

Above. In a uniform ice chunk, electrons spread out evenly and generate a weak electric field.

Right. In a lengthy ice shard, electrons crowd into the tip, enhancing the electric field.

Then physicists started looking at storms from space and learned that thunderclouds were stranger than they had imagined.

Runaway Avalanches



In 1752, Benjamin Franklin conducted his famous kite experiment, as depicted in this c. 1816 painting by Benjamin West. This experiment established the connection between lightning and electricity. Public Domain

In 1994, a satellite searching for extreme deep-space explosions happened to pick up flashes of gamma rays coming from thunderclouds, often alongside lightning. Gamma rays are the most energetic type of light rays, typically marking the last gasp of a dying star or the cataclysmic clap of two neutron stars. They are not something you would expect to come out of a cloud, no matter how many sharp ice chips it had. Something was afoot in the fast and intense realm of subatomic particles.

This was around the time that Dwyer witnessed the booming Floridian lightning storms and learned about their mysterious origins. As an astrophysicist, he knew about the subatomic realm. He was familiar with the work of the Nobel laureate C.T.R. Wilson, who had hypothesized that a "relativistic" electron moving at close to the speed of light would barely feel any drag from atoms in the air.

(Continued on page 46)

(What Causes Lightning from page 45)

(Da Silva likens it to a bullet ripping through a flurry of snowflakes.) A sufficiently speedy electron in an electric field could therefore “run-away” faster and faster.

Dwyer knew that a Russian physicist, Aleksandr Gurevich, had shown in 1992 that such a runaway electron could unleash a cascade of perhaps 100 000 electrons, akin to the avalanches that initiate sparks in the lab but playing out over hundreds to thousands of metres. And he also knew that when these relativistic, runaway electrons bounced off air molecules, they could emit gamma rays.

By themselves, these extreme subatomic affairs did not seem to be abundant enough to account for the brilliant gamma rays lighting up storm clouds.

But then Dwyer imagined a baroque process that could allow one avalanche to set off another and another and another, all right on top of each other.

According to Dwyer’s process, when one electron in the avalanche collided with an atom,

the electron could ricochet and emit a gamma ray. That gamma ray would transform into an electron and its antimatter twin, a positron. The cloud’s electric field would push the positron backward close to where the avalanche began. There it could crash into another atom, setting off another avalanche, which would make more gamma rays, more positrons, more avalanches and so on, until you got a flash visible from orbit.

“It’s like taking a microphone and sticking it next to a speaker,” said Dwyer, who is now at the University of New Hampshire. “It can get really loud quick.”

The stack of runaway relativistic avalanches could explain the gamma rays. And it could also contribute to lightning initiation. As the avalanche cascades, electrons pile up at the front while leaving positively charged ions in their wake — boosting the cloud’s electric field.

In computer simulations, Dwyer showed that this chain of events amplified avalanches, radiated gamma rays and ramped up the electric field. Around the same time, detailed simulations of ice shards revealed how sharp they were likely to get — not very sharp — which also began to weaken the hydrometeor theory.

So, were Dwyer’s runaway relativistic avalanches really happening inside clouds? And could this boost the electric field enough to produce lightning? His colleagues were divided.

Researchers needed to get closer to the action. In July 2023, daredevil physicists outfitted a high-altitude NASA plane with gamma-ray detectors and flew it straight over the core of some of the most ferocious storms on the planet — tropical storms in the Gulf of Mexico, the Caribbean and Central America. The plane reached stratospheric perches that “most people would like to avoid at all costs,” da Silva said. The campaign was called [ALOFT](#), an acronym made in part from other acronyms. Its observations delivered the biggest bonanza of new data in a generation.

Storm clouds, ALOFT revealed, are bubbling cauldrons emitting all sorts of gamma rays that are too faint to see from space. The project confirmed the soft glows and sudden flashes around lightning that space-based instruments had also detected. But ALOFT also detected that clouds flash even

(Continued on page 47)



Lightning is common in Florida. This strike hit the launchpad of the Space Shuttle Challenger at Kennedy Space Centre on 30 August 1983. NASA

(What Causes Lightning from page 46)

when no lightning is visible. Most curiously, they also flicker.

“They discovered there is a whole zoo of other phenomena,” said Ute Ebert, a lightning physicist at Eindhoven University of Technology in the Netherlands.

One person who was not completely surprised by the ALOFT observations was Dwyer. In anticipation of the ALOFT team’s announcement, he had rerun his simulations to predict what their gamma-ray detector would see as it flew above the storms. He had long known that the relativistic avalanches unavoidably piled up in a flickering pattern, so he calculated exactly what kind of flicker the particle collisions would produce. Both teams presented their findings in San Francisco at the American Geophysical Union’s annual meeting in December 2023 and the results lined right up — the strongest evidence yet that Dwyer’s subatomic collisions are playing out inside real thunderstorms.

Now other theorists are building upon this theory. Last summer, Victor Pasko, an electrical engineer at Pennsylvania State University, studied the chain of events set off under other circumstances, such as higher electric fields and found that in these cases too avalanches can pile up and initiate lightning, lending additional support to the whole framework.

“It’s consolidating this idea that the energetic electrons are playing a role here,” da Silva said. “Until very recently, essentially just Dwyer was



To trigger lightning, researchers fire a small rocket with a thin, grounded metal wire into a charged thundercloud. The wire initiates a lightning strike on command. UF/FIT ICLRT. <https://www.quantamagazine.org/wp-content/uploads/2026/05/Rocket-Triggered-Lightning-cr-University-of-Florida-Florida-Institute-of-Technology-and-Southwest-Research-Institute.mp4>

talking about this.”

At Odds With The Field

Chains of high-energy electron avalanches may very likely be making clouds glow, flicker and flash with gamma rays. But researchers can’t say with certainty that they are also sparking lightning. One puzzle is that lightning seems to start from one point in the cloud, while the avalanches take place over a much larger region. The avalanches bring the cloud close to the conditions that are expected to lead to lightning. But no one has fully connected them to the triggering of a lightning bolt.

Even as Dwyer’s theory has gained support,

(Continued on page 48)



The NASA ALOFT mission used a high-altitude ER-2 aircraft (left) with pilots (right) flying directly over tropical thunderstorms to detect high-energy particles and radiation associated with lightning. NASA/Carla Thomas

(What Causes Lightning from page 47)

observations from early 2025 have revived yet another theory of lightning creation.

In the New Mexico desert, a pair of stations bristling with antennas captured radio waves coming out of a dozen separate lightning strikes. Using this data, Xuan-Min Shao, a researcher at Los Alamos National Laboratory, was able to reconstruct the way the overall current moved during the start of these strikes. He found that something was off. If one of Dwyer's cascades, or any other process driven purely by the electric field, was seeding the lightning bolt, the proto-bolt would move perfectly in line with the electric field from the very beginning of the process. But Shao [found](#) that in these cases, the two directions were slightly at odds. In the slant, Shao sees evidence for an extraterrestrial, even extragalactic origin for lightning — a cosmic-ray shower.

Cosmic-ray showers are the result of violent events in deep space, such as the expulsion of particles from feeding black holes or stellar explosions that fire off a piece of atomic shrapnel — perhaps a proton from an exploding star, or a denuded iron atom expelled from a supermassive black hole. These shards travel billions of light-years across the universe and slam into Earth's atmosphere. The violent collision sprays a jet of electrons, positrons and other particles down into a cloud at a random angle. These electrons and positrons could have enough oomph to separate

the electrons from their molecules and get an avalanche going, even if the electric field stays well below the critical threshold.

To some physicists, Shao makes a strong case. "It has to be mapping the direction of something else, most likely the cosmic-ray ionization," said David Smith, a physicist at the University of California, Santa Cruz. "I find the data extremely convincing."

Others say it is too soon to know what to make of the finding. Shao's reconstruction technique is not fully established and cosmic-ray showers are full of poorly understood particle physics. That makes it tempting to use them as a "magic wand," said Brian Hare, a physicist at the Netherlands Institute for Radio Astronomy, to fill an otherwise hard-to-explain gap in a mysterious process.

But if Shao and others start to see more instances of lightning flying askew, that might motivate theorists to work out those details.

"It's a really cool idea and there's a hint that this might be going on," Dwyer said. "If this mechanism is true, every time you see a lightning flash, there is a physical connection to a dying star somewhere in the galaxy."

The last few decades of lightning research have produced a handful of ideas for how nature may coax lightning bolts from clouds with weak electric fields. And while the theories compete in the scientific literature, they likely collaborate in the real world. Long needles of ice may set off bolts in one cloud while a deluge of electrons producing gamma rays does it in another cloud. And multiple mechanisms may work together to push the electric field past the point of no return. Only with more precise measurements of the gamma rays and radio waves that accompany lightning can researchers hope to determine whether one mechanism, or one combination of mechanisms, is the most common.

But as physicists close in on the mystery of what initiates lightning, they are once again spotting unexpected occurrences that don't

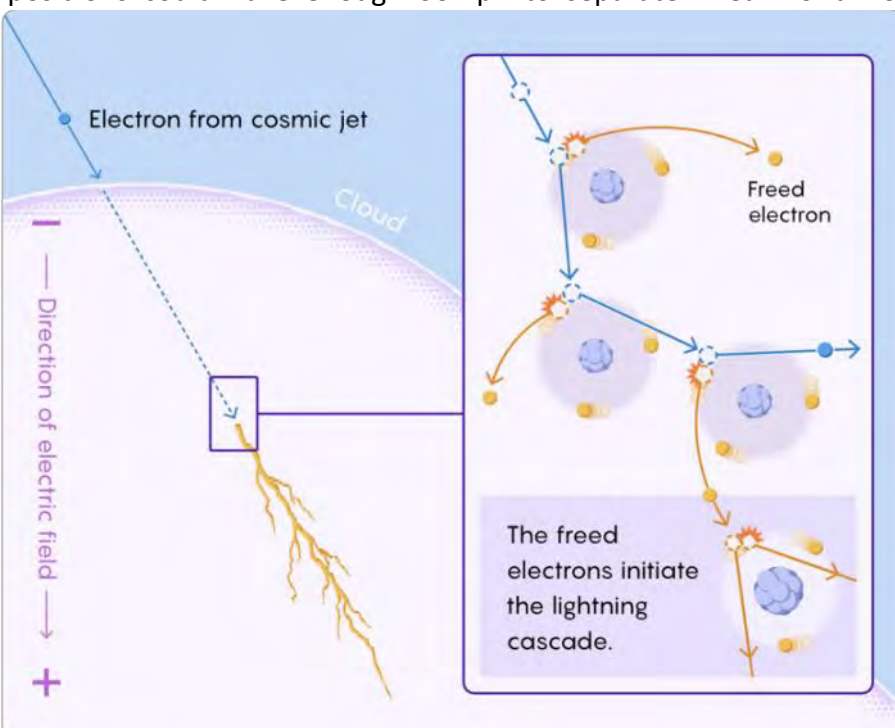

(Continued on page 49)

(What Causes Lightning from page 48)

fit any of the theories. There are subtle patterns in the gamma rays ALOFT saw, for instance. And over the last few years, [a radio telescope array in the Netherlands](#) has been providing some of the sharpest images yet of lightning as it begins to branch out from its starting point. They show that some parts shoot out quickly, some move relatively slowly and some sprout needles as they travel. These features suggest that even as explanations get more comprehensive, the case of how lightning really works will keep getting reopened. "It just gets more and more bizarre the more we look," Dwyer said. "Clearly our very simple pictures here are really incomplete."

By capturing radio waves from a dozen individual lightning strikes, Xuan-Min Shao has found evidence that cosmic-ray showers may trigger lightning. Los Alamos National Laboratory



The ZS0BOT low-power Beacon

Jan Botha, ZS4JAN, ZT4T and ZS0BOT/b

I am the owner of a HF QRPP unpowered CW beacon on 7,027 MHz. The call sign is ZS0BOT. The beacon is licensed as an unmanned device by the Independent Communications Authority of South Africa. The beacon is powered by a solar module with two 7A/h battery packs.

Purpose of the Beacon

To test local NVIS propagation on 40 m with very low RF power. This all is done from the central part of South Africa.

Beacon Details

1. Frequency 7,027 MHz.
2. Transmitting output RF power 50 milliwatts.
3. Beacon message: **VVV DE ZS0BOT/B KG30BV.** The message is transmitted at 5 WPM in an endless loop.
4. The beacon was designed, built, software written and programmed by ZS4JAN.
5. The NVIS antenna is inverted V dipole. Height is 6 metres sloping down to 1,8 metres. Orientation is North/South.
6. The power supply is a 10-Watt solar module

The cabinet housing the Beacon. (I understand the beacon does not work, if the lock on the outside is not a Tri-Circle lock! Ed.)



(Launching Satellites from page 49)

trickle charging two 7 A/h battery packs. The voltage regulator/charger was designed and built by ZS4JAN.

The beacon project started off as a basic project. This project gave me new insight in the world of small RF power. Test equipment had to be built to measure the very low RF power accurately. This was my first attempt in programming a PIC with a CW message in MicroBasic.

The beacon is transmitting since 15 April 2010. This is some basic information regarding this little, but very useful beacon.

If you do copy this beacon, please send me a detailed e-mail with a RST report to wirelesscomms@vodamail.co.za.

If you require detailed information and photos about myself and my station, please visit ZS4JAN@QRZ.com.

Visit <https://hfbeacons.wordpress.com/hf->



The Antenna Switch, the ZS0BOT beacon, the Cell Controller, the Solar Regulator/charger, two 7 A/h Battery packs and the GSM module

[beacons/](#) to find out more about the various HF Beacons around the world.



The ZS0BOT/beacon, the Antena Switch, the Cell Controller and the Solar Regulator modules

A **beacon** is an intentionally conspicuous device designed to attract attention to a specific location. A common example is the lighthouse, which draws attention to a fixed point that can be used to navigate around obstacles or into port. More modern examples include a variety of radio beacons that can be read on radio direction finders in all weather and radar transponders that appear on radar displays.

Radio propagation beacons are used by amateur radio operators and organizations for measuring propagation of radio waves. These beacon stations are installed at fixed locations and transmit regularly on specific radio frequencies. The signals from these beacons can then be received by other amateur radio stations in order to determine the feasibility of communication with other regions.

Number stations - Ghosts on the Shortwave Bands

Charl Maritz, ZS1ZZ first published in Ragchew, May 2026



Voices in the Ether

It is late at night. You are slowly spinning the dial of your shortwave receiver, crossing the forty-metre band. Static, broadcast voices in distant languages, perhaps the warble of a digital mode and then, something else. A calm, emotionless voice begins reading groups of numbers in slow, deliberate tones. Five digits at a time. No call sign. No station ID. No explanation. Just numbers, repeated with mechanical precision and then silence.

You have encountered one of the most enduring mysteries of the radio spectrum: a numbers station. For over a century these enigmatic transmissions have haunted the shortwave bands, carrying encrypted messages to spies and intelligence operatives scattered across the globe. They are officially unacknowledged by the governments that operate them, technically illegal under ITU regulations and yet as events in early 2026 dramatically confirmed they are very much alive.

The One-Time Pad: An Unbreakable Cipher

To understand why numbers stations exist, you need to understand the cryptographic system that makes them worth operating: the one-time pad

(OTP). Developed formally around 1917 - 1919 by Gilbert Vernam and Joseph Mauborgne of the US Army, the principle is simple. If you encrypt a message using a random key that is exactly as long as the message, used only once and kept perfectly secret, the resulting cipher is mathematically unbreakable not merely difficult to crack, but theoretically impossible to decode without the key. Even with unlimited computing power, an adversary cannot determine whether the text says, "attack at dawn" or "bring milk and beers."

Combine an unbreakable cipher with the global reach of shortwave radio HF signals that propagate thousands of kilometres by bouncing off the ionosphere and the numbers station concept emerges almost inevitably. An agency creates a one-time pad, gives one copy to their field agent and retains the other. At a prearranged time and frequency, a broadcast goes out: groups of numbers read by a neutral voice. The agent writes them down, applies the pad arithmetically and reads the message. No computer required. No internet connection. No detectable transmission from the receiving end. Just a shortwave receiver, a pencil and a piece of paper.

(Continued on page 52)

(Numbers Stations from page 51)

A Century of Clandestine Broadcasts

While numbers stations almost certainly operated during both World Wars, their use was compounded during the Cold War. From the late 1940s through the Soviet collapse in 1991, the shortwave spectrum was thick with clandestine broadcasts from agencies on every side of the geopolitical divide. Western listeners stumbled across them accidentally, amateur operators and shortwave hobbyists gradually recognised reoccurring patterns: the same frequencies, the same schedules, the same distinctive introductions.

Famous Stations

The Lincolnshire Poacher (designated E03 by the monitoring community) was perhaps the most famous English-language station, named for its musical introduction the first bars of the traditional folk song. Widely attributed to Britain's MI6, broadcasting from Akrotiri in Cyprus, it transmitted to agents in Eastern Europe and the Middle East for decades before going silent around 2008.

The Buzzer, known in Russian as Zhuzhzhalka, has broadcast a near continuous repetitive buzzing tone on 4 625 kHz since the 1970s, interrupted only occasionally by terse voice messages. Its purpose remains debated. What is not debated is that it is still transmitting as of 2026, making it one of the longest running continuous transmissions in radio history.

The Cuban HM01 station, known as Atencion, broadcast Spanish five-digit groups to Cuban intelligence agents in the United States for years. Its existence was confirmed beyond doubt during the trial of the Cuban Five intelligence officers arrested in the US in 1998 making HM01 one of the very few numbers stations whose operational

purpose was formally established in an open court of law.

The Conet Project

In 1997, the British label Irdial Discs released The Conet Project, a four-disc compilation of numbers station recordings gathered by hobbyists over many years. The release brought the phenomenon to wider public attention, confirming what listeners had long suspected: these were not random anomalies but systematic, purposeful transmissions with consistent formats and schedules and they were coming from governments.



How Monitoring Works: Priyom and the Community

The task of cataloguing numbers stations fall to a global community of dedicated shortwave listeners. The most significant modern effort is Priyom.org, a volunteer network that maintains live schedules, archives recordings and publishes technical analyses of active stations worldwide. Priyom uses the ENIGMA nomenclature system prefix letters indicating language or signal type (E for English, G for German, V for various, S for Slavic) followed by a number allowing uniform cross reference across monitoring reports from different listeners on different continents.

The monitoring toolkit has never been more accessible. A software defined radio (SDR) dongle costing a few hundred rand, paired with any reasonable HF antenna and free software such as SDR# or GQRX, is sufficient to receive most active stations. The Kiwi SDR network a global array of web-based receivers operated by hobbyists allows anyone to tune a receiver on the other side of the world through a browser. Numbers stations that are inaudible from southern Africa due to propagation can often be received clearly on a Kiwi SDR in central Europe.

Why the Internet Has Not Killed Them

There are those who have periodically declared numbers stations obsolete Cold War relics clinging to life in an age of encrypted smartphones and

(Continued on page 53)



(Numbers Stations from page 52)

VPNs. The argument sounds reasonable until you examine the threat model. Internet communications, however well encrypted, leaves metadata, connection logs, IP addresses, timing signatures, cell tower records. An agent operating in a hostile country may find that internet infrastructure is monitored, restricted, or simply unavailable. Several well publicised cases have demonstrated that even "secure" messaging applications can be compromised at the endpoint.

A shortwave receiver, by contrast, leaves no trace at all. There is no connection to establish, no packet to log, no satellite handshake to intercept. The agent does not acknowledge receipt. The broadcast simply goes out and either reaches them or it does not. This passive reception model, combined with the mathematical certainty of a one-time pad, gives numbers stations a safety net that no digital system can fully replicate under adversarial conditions. The content of the message is protected by cryptography. The act of receiving it is invisible.

V32 - 7 910 kHz: Proof of Concept, February 2026

On 28 February 2026 about twelve hours after the first US airstrikes against Iran that opened the current conflict there was a new signal which appeared on 7 910 kHz USB. A male voice, calm and measured, began reading structured five-digit numeric groups in Farsi, the Persian language spoken by some eighty million Iranians. No call sign. No identification. Twice a day, at 18:00 UTC and 02:00 UTC, with transmissions lasting up to two hours.

The station, designated V32 by Priyom, was logged within its first minute of transmission. Technical analysis quickly turned up a remarkable detail: a periodic dual tone beep audible beneath the voice, identified by experienced monitors as the plain text override warning tone generated automatically by L3Harris military grade radio equipment operated by Western military and intelligence services. Signal triangulation using the global Kiwi SDR network placed the likely transmission origin outside Iran, with analysis eventually pointing toward central Europe.

Iran's response was swift and unmistakable. From 4 March, the Iranian bubble jammer, the



same pulsing interference signal Tehran has long used to block Radio Farda and BBC Persian from reaching the country appeared on 7 910 kHz during V32's transmission windows. A government does not jam its own station. The jamming confirmed, as clearly as any official statement could, that V32 was being received inside Iran and that Tehran wanted it stopped.

What followed was a modern cat and mouse game played out in full view of the global monitoring community. V32 moved to 7 842 kHz. The Iranian jammer followed. V32 returned to 7 910 kHz on 18 March in a new format iteration. The jammer followed again with a second interference signal a continuous 1 000 Hz AM tone from an unknown source joined the effort from 20 March.

Regular high-power transmissions effectively ceased after 25 March, though extremely faint signals consistent with the same equipment were still being logged in early April.

The significance of V32 for our discussion is not who operated it or what the messages said both remain officially unconfirmed. The importance is the timing. When an active military conflict erupted involving one of the world's most tightly controlled internet environments, a numbers station was on the air within twelve hours. Not a secure app. Not a satellite phone. A shortwave transmitter, a one-time pad and a frequency that any agent with a basic receiver could tune.

Numbers stations are, simultaneously, the simplest and the most mysterious objects in the radio spectrum. A carrier wave, a voice reading numbers and beneath that, implications reaching from the physics of the ionosphere to the

(Continued on page 54)



(Numbers Stations from page 53)

operational security of intelligence services worldwide. They have outlasted every prediction of their demise, adapted through various geopolitical landscape and continued to transmit through every era of technological change.

For those of us who operate in the HF bands who spend evenings listening to signals across the planet with wire antennas and modest power there is something both sobering and electrifying about sharing those frequencies with these ghost signals. The one-time pad has never been broken. HF propagation has not changed. And somewhere out there, on a frequency not far from where you run your FT8 or your SSB, a calm voice is reading numbers to someone who very much needs to hear them.

Keep your ears open

Reference pages used for this article: Priyom.org; SWLing Post - March 2026; IZOKBA Lorenzo monitoring blog; The Conet Project, Irdial Discs, 1997; Shortwave Radio Forum - V32 reception reports

For further reference or monitoring hereby a

list of websites for your perusal:

<https://priyom.org/number-stations/station-schedule> this is a brilliant website where most of the station schedules are posted.

https://en.wikipedia.org/wiki/Numbers_station
<http://www.signalshed.com>

The SARL Top Band QSO Party

Are you setup for the SARL Top Band QSO Party? The contest runs from 22:01 UTC Thursday 4 June (midnight CAT) to 21:59 UTC on Sunday 7 June 2026 with CW, digital and Phone activity. The exchange is a RS, RSQ or RST report and your 4-character grid square (e.g. KG13). Submit your log sheet by 21:59 UTC on Friday 12 June 2026 by e-mail to contest@zs6wr.co.za. Remember to apply for your SARL Top Band Award.

The SARL VHF/UHF FM Contest

The SARL VHF/UHF FM contest provides you with a chance to test your VHF/UHF equipment and see how far you can chat on FM. Everyone can take part, whether you are a portable or mobile operator, an off-road specialist or a home station. Remember height gives you an advantage - how far

(Continued on page 127)

The WT3J GUI-Based Morse Code Controller

John Wiseman, CT9/WT3J first published in QST, July 2024

This CW controller will help you efficiently break through pileups at a minimal cost.

I have several radios; some of them have CW memories and some do not. The CW controller system shown in the lead photo works with all my radios without the need for wiring or configuration changes. This is accomplished with a modular software architecture that is easily modified to include future features.

Main Components Required

The system uses a Raspberry Pi 4 as the processor, along with a home-built hardware interface module that provides ground-isolated connections between the Raspberry Pi interface bus and a radio's CW key input. I use two versions of this system. One version is used with a large 4K monitor, keyboard and mouse for my main radio in a fixed desktop configuration. I use the second version for portable operation and it drives a small HO-resolution touchscreen with an integrated keyboard. A complete *Python 3* software application that includes a separate data file containing 20 user-definable Morse code sequences is available at www.arrl.org/qst-in-depth.

Raspberry Pi GPIO and interface Module Connections

The Raspberry Pi communicates via the general-purpose input/output (GPIO) bus. Only three GPIO pins are used. These operate two optically isolated, solid-state relays and a transmitting status LED in the interface module. The interface module schematic is shown in Figure 1 and the parts list is given in Table 1. For any readers interested, I can provide a printed circuit board ExpressPCB layout, but a prototype board implementation works well. A seven-wire ribbon cable connects the Raspberry



The code controller system with the graphical user interface (GUI)

Pi to the interface module. The three signal lines with four alternating ground lines help prevent RF interference. The interface module's 3,5-millimetre jack connects to the radio's key input and the other 3,5-millimetre key jack is used for a straight key input. The outputs of the solid-state relays and the external key are wired in parallel and either can be used during a CW contact. When the Raspberry Pi is powered down, the optical couplers will not engage. So, the regular CW keys will remain functional. Once the interface module is connected to your Raspberry Pi (see Figure 2), you are ready to download and run the system software. The basic software design and implementation are detailed at www.arrl.org/qst-in-depth.

Sending CW

Once the system is running, it is time to send a Morse sequence to the radio. I suggest sending "QRL?" first with your key and then again by typing "QRL?" into the first text buffer and clicking on the radio button labelled **TRANSMIT TEXT BUFFER A** in the graphical user interface (GUI) to make sure

(Continued on page 56)

Table 1. Interface Module Parts List

| Quantity | Description | Designation |
|----------|--|-------------|
| 3 | 330 Ω 1/8 W resistor | A1, A2, A3 |
| 1 | LED (any colour or brightness) | D1 |
| 2 | 3.5-millimeter three-conductor stereo jack | J1, J2 |
| 2 | Solid-state relay, Mouser Electronics 78-VOA1121A6 | IC1, IC2 |

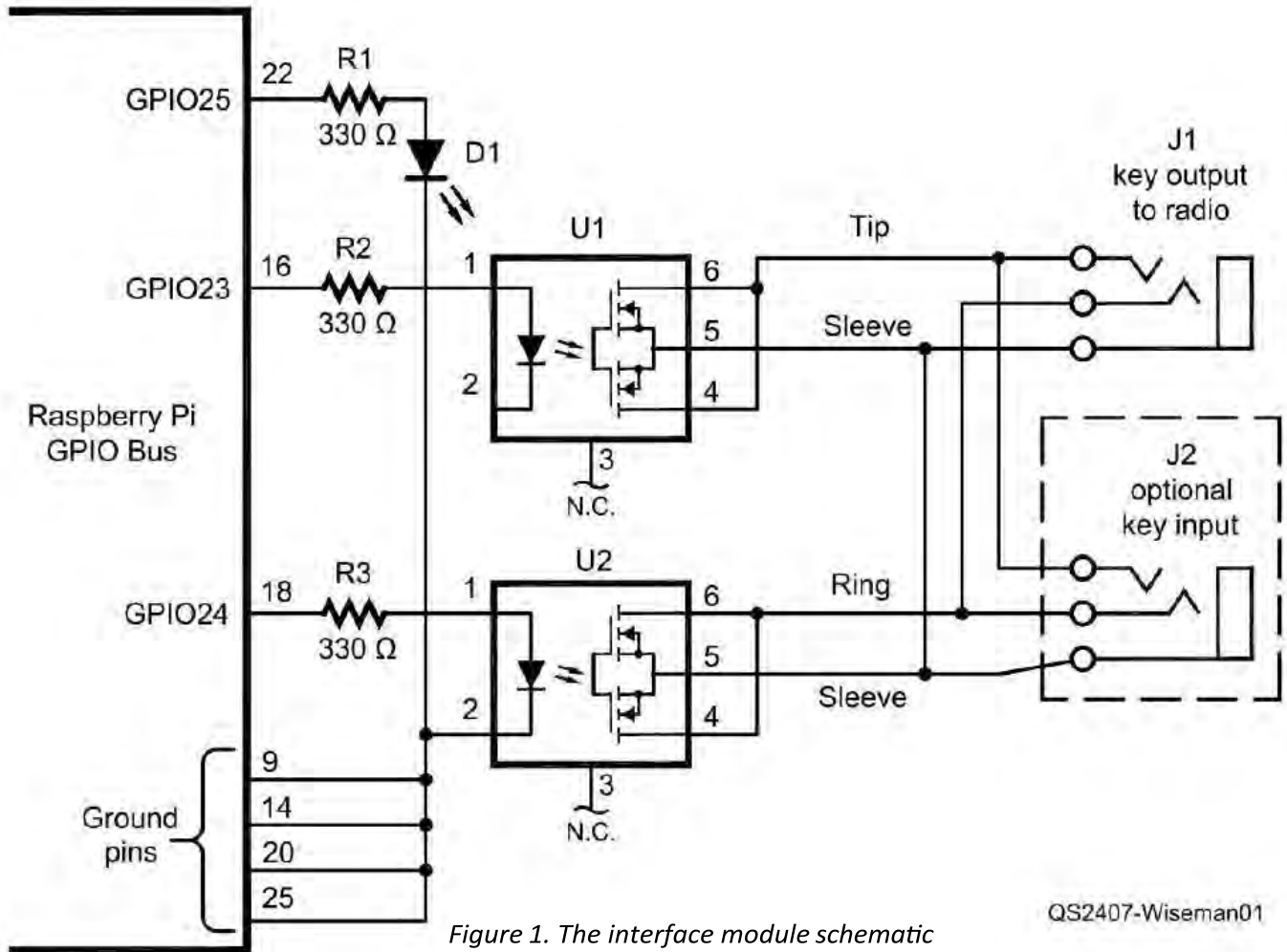

Figure 1. The interface module schematic

(Morse Code Controller from page 55)

everything is operating correctly.

At this point, it is off to the airwaves. You can complete an entire contact using only a mouse or touchscreen to click the appropriate radio buttons and the alternating text boxes with input directly from your keyboard. The use of alternate inputs allows a “ping-pong” approach, where one box may be updated while the other is streaming out to the radio. Corrections can be made in advance, as each box allows for full editing before it is enabled to transmit. Because a regular key is wired in parallel, you can augment your transmission at any time. More photographs pertaining to the system can be seen at www.arrl.org/qst-in-depth.

Basic Software Design and Implementation

The software, written in Python 3, was designed and debugged using the Thonny Integrated Development Environment (JOE). The GUI was

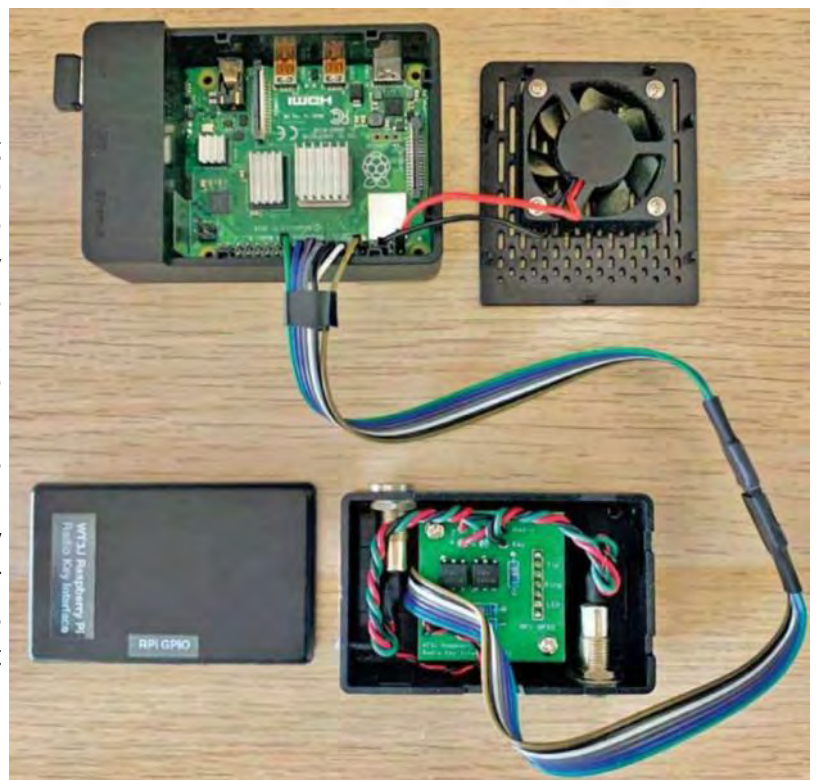

Figure 2. Raspberry Pi and interface module connections.

(Continued on page 57)

(Morse Code Controller from page 56)

developed using Tkinter. These packages are pre-loaded into Raspbian, the Raspberry Pi operating system. As Python is an interpreted language, it runs directly when invoked. It does not require compilation and linking stages.

The *Python* software design is broken up into what are known as *functions*. Programming in this style is analogous to performing hardware design in a modular fashion. This results in a series of elements that can be individually built and tested and then combined into a system as you go. In the end, this also allows greater flexibility for adding or improving individual portions of the design later without having to significantly modify other areas.

A detailed description of the low-level character processing can be accessed by tracing through the software using the *Thonny JOE* on the Raspberry Pi. Being of a modular, functional design style, it is relatively easy to read, trace through, understand and modify. The source code has extensive comments embedded throughout to help with this process. The *Python* system code and the associated program data file listings are provided at www.arrl.org/gst-in-depth.

All photos provided by the author.

John Wiseman, WT3J, was first licensed in 1985. His mentor and Novice-class license administrator



Click here https://www.youtube.com/playlist?list=PLuaplzKwhZN8NjGS_E_u2oETuqG4G5uvh to watch a seven-video playlist of John Wiseman, CT9/WT3J, demonstrating the WT3J GUI-based Morse code controller.

was Dave Benson, K1SWL, of Small Wonder Labs. John holds a BSEE from the University of Massachusetts Amherst and an MSEE from the University of New Mexico. He recently retired from a 40+ year career specializing in video technologies and applications. He enjoys designing hard-ware and software projects for his shack, especially those related to CW applications. He and his wife recently moved to Madeira Island, where he is using the call sign CT9/WT3J. Besides being involved in amateur radio, John is also an avid motorcyclist and he takes Portuguese language classes. He can be reached at ct9.wt3j@gmail.com.

The YL.Beam

Heather Holland, ZS5YH

Helen Archibald, VA1YL - RAC Amateur of the Year

The RAC Board of Directors takes great pleasure in selecting Fred Archibald, VE1FA and Helen Archibald, VA1YL of Port Williams, Nova Scotia as the recipients of the RAC Amateur of the Year

Award for 2025.

Through the RAC Amateur of the Year Award, Radio Amateurs of Canada recognizes

the outstanding contributions made by Canadian Amateurs. Fred and Helen Archibald have been pillars of Amateur Radio in Canada for decades. While the award traditionally reflects contributions within a given year, their sustained excellence in 2025 – combined with a lifetime of service – made them compelling joint recipients.

(Continued on page 58)

Fred, VE1FA and Helen, VA1YL Archibald - Amateurs of the Year 2025 and their daughter Margaret, VE2ZOO on Walrus island (NA-121)



(The YL Beam from page 57)

Together, they have organized and operated more than two dozen DXpeditions, activating rare Canadian islands for DXCC and Islands On The Air (IOTA). Their contest efforts have consistently ranked among the top stations in North America, with several Top 10 world-wide finishes in the IOTA Contest.

Fred is widely respected as an instructor, technical innovator and equipment restorer, having mentored numerous new Amateurs and restored historic communications equipment for museum exhibits.

Helen has served as President of the Canadian Ladies Amateur Radio Association (CLARA), long-time net controller, course instructor and youth outreach advocate through Guides On The Air and Jamboree On The Air (JOTA).

For many years, they have opened their station for the RAC Winter and Canada Day Contests and have been strong contributors to Field Day activities, demonstrating operating excellence and sportsmanship.

Their partnership – spanning more than 50 years of marriage and decades of Amateur Radio dedication – reflects team work, resilience and service at the highest level.

Radio Amateurs of Canada sincerely congratulates Fred Archibald, VE1FA and Helen Archibald, VA1YL on being named the RAC Amateurs of the Year for 2025.

Allan Boyd, VE3AJB, RAC President, 21 February 2026

Guides On The Air (GOTA) was started in 1985 as part of the celebration of 75 years of Girl Guides. It is an opportunity for Girl Guides to talk on amateur radio. The idea was for Guides to speak to other Guides on the radio. It spread from Canada around the world. Outside Canada it is known as Thinking Day on the Air (TDOTA).

Helen Archibald VA1YL, formerly VE2GGQ, has continued to operate GOTA almost every year since she became an amateur operator in 1992. Since 1999, over 600 Guides and Guiders have visited her radio room to participate in GOTA. In 2016, 70 members of Guides Canada participated at Helen's radio shack. 47 girls or women spoke on amateur radio to 14 stations in Germany, England, USA,

Belgium, Wales, Italy, Ireland, Northern Ireland and Canada.

Helen Archibald, Hardwood Lake Trefoil Guild <https://www.girlguides.ca/WEB/Documents/NS/6/coastlines/cst-sum16.pdf>

Valerie Hotzfeld, NV9L interviews Helen Archibald, VA1YL on 24 September 2016. Helen has been on 20+ DXpeditions. <https://www.youtube.com/watch?app=desktop&v=nL6VWJCPFWE>.

More From Canada

This is the logo I made for our inaugural London Amateur Radio Club YL event. We had 9 of our 12 YLs turn out. We used one of our club registered call signs: VE3PFL. We activated at POTA location: Fanshawe Conservation Area is CA-5936.

Cheers, Carrolleigh Cecile, VE3CBD.



More Awards

Daphne Newsum, G7ENA was awarded the Don Cameron G4STT Award by the RSGB on 18 April 2026. This award is given for outstanding contribution to low power amateur radio communication.

During the 66th All Asian DX Phone Contest in 2025, Rosa Tapia, CE1RT achieved first place in the 15 m Low Power class in Chile as well as South America. The awarded was presented by JARL (Japanese Amateur Radio League).

Christiane Rester, DL3CR. I had the great pleasure of receiving the Pin of Honor of the District of Rhineland-Palatinate (Germany). This award was given to me for my joint work in the L.M.T. Group. The cooperation in this group has always been special to me because it is characterized by commitment, team spirit and mutual support.

I would like to emphasize that I am not a member of the district of Rhineland-Palatinate, but I belong to District Q. This is exactly why this honour means a lot to me, as it represents a recognition beyond one's own district boundaries.

(Continued on page 59)

(The YL.Beam from page 58)

This award surprised me even more and at the same time made me very happy. For me, it is not only a personal honour, but also an appreciation of the joint work and dedication within the L.M.T. group.



Île Roume (Roume Island) Los Archipelago (Los Islands)

Latitude: 9° 27' 48" N. Longitude: 13° 47' 33" W.

It is one of the three main islands in the group located off the coast of Conakry, capital of Guinea in West Africa. characterized by a tropical climate and rocky terrain.

Roume Island is the central and smallest of the inhabited islands in the archipelago and the centre of what remains of a volcano.

The village of Roume is located on the northern coast of the island, accessible by boat and sheltered from the Atlantic Ocean swell. A palm grove occupies most of the arable land, which is not very extensive on this predominantly rocky island. Most of the island is walkable. The small island population has specialized mainly in fishing and in recent years in tourism during the dry seasons. (December – May). French is the official language, but regional languages dominate.

3X3A DXpedition Île de Roume – Guinea (AF-051)

11 to 25 April with CW, phone and digital activity will focus on 80 to 10 m and 6 m. It was a single operator DXpedition with the goal to maximize

worldwide QSOs. Roume Island is a rare IOTA reference especially in Europe and North America. This DXpedition is self-funded.



Elvira Simoncini, 3X3A and IV3FSG (extracts taken from Facebook)

Yesterday evening (16 April 2026) finally fired up the engines on 80 m FT8 and the pile-up was absolutely incredible. It is a real pleasure to hear so many friends on the air. Thank you all for your patience if the signal suddenly drops... electricity here is definitely an optional luxury!

It is not all DX and clean signals here at 3X3A. Today, (18 April) the reality of this solo mission really hit home: my generator decided to act up. Out here, power is my oxygen and whenever the engine stutters, my heart skips a beat. On top of managing everything on my own, I am fighting the electrical noise that is blurring the bands just as I am trying to pull weak signals out of the static. Between hauling fuel cans and tweaking filters, I am doing everything I can to stay on the air. I am tired, but the game has just begun.

21 April 2026 The 60 m (5 MHz) band was buzzing tonight! For the first time, the 3X prefix was broadcast on this frequency and the flood of calls was literally overwhelming. Being the first to make a connection from Guinea over 60 metres is an incredible feeling. Signals coming from everywhere, electrifying propagation and the satisfaction of having given a "New" contact to so many friends

(Continued on page 60)

(The YL Beam from page 59)

around the world. Thanks to all who patiently waited their turn amidst the chaotic signals. Guinea is officially on the 60 m chart and tonight will be etched in history!

Tomorrow, 25 April, my adventure here on Rouse Island will come to an end. I will do my best to get as many as possible into the log before taking down the antennas.

25 April 2026 3X3A – Final greetings from Rouse Island. There is always a moment, at the end of a DXpedition, when everything slows down. Tonight, will be the last “on the air” night. Then I will take down the antennas and this experience in Guinea will remain as memory and radio waves. Two intense weeks, with continuous pile-ups and propagation that was not always easy. But also, a strong emotion: bringing the 3X prefix on 60 metres for the first time and hearing you emerge from the noise. Thank you for looking for me, waiting and listening — even when I was just barely there. 73 de Elvira, 3X3A

Late News!



Elvira Simoncini, IV3FSG, accepts her Heritage CQ DX Hall of Fame plaque from INDEXA Vice President Bob Schenck, N200. [Rich Moseson, W2VU, photo]

The Heritage CQ DX Hall of Fame, launched in 1967 and currently administered by INDEXA, the International DX Association, welcomed two new members, legendary QSL manager Charles Wilmott, MØOXO and avid DXpeditioner Elvira Simoncini, IV3FSG. Elvira, who has operated from 34 different DXCC entities, is only the third woman inducted and the first to be so honoured individually rather than with her husband.

Out-and-About

Deena, VK6DEE and Mark, VK6BSA are now based on Cocos (Keeling) Islands for a work assignment until May, possibly longer. During free time they are active as VK9BSA and VK9DEE on most bands using a FTDX-10. The Cocos (Keeling) Islands are an Australian external territory located in the Indian Ocean, comprising a small archipelago approximately midway between Australia and Sri Lanka and relatively close to the Indonesian island of Sumatra.



World Amateur Radio Day

On World Amateur Radio Day, 18 April 2026 Doreen Bogdan-Martin, KD2JTX who is the current ITU Secretary-General, talked about Amateur Radio. <https://www.facebook.com/reel/979637937915352>

Angola, D2

My name is Isabel Machado and I operate under the call sign D2IM from Angola. My journey in amateur radio started in Portugal, where I am also licensed as CR7BZL. Over the years, my connection with the hobby grew naturally through

(Continued on page 61)



(The YL.Beam from page 60)

close contact with the amateur radio community and participation in several initiatives, including the organization of DXpeditions. Although I had not yet operated as an active station during those events, the experience allowed me to better understand the spirit of amateur radio, its technical challenges and, above all, its strong sense of global community.

Motivated by this environment and the people I met along the way; my interest gradually turned into a true passion. In 2026, I obtained my license in Angola, becoming D2IM and officially started my activity on the air.

Today, I am proud to be the only YL (female operator) currently active in Angola and I hope to contribute to promoting amateur radio in the region, while continuing to learn, evolve and make contacts around the world.

I enjoy operating different modes and making DX contacts, always with the goal of improving my skills and expanding my reach across bands and continents.

Thank you for visiting my page (QRZ.com) and I



look forward to working you on the air!
73, Isabel Machado, D2IM

HF Station: ICOM IC-718; Yaesu FT-857; Yaesu FTDx10; XR3 Antenna (Inovantennas) – 10 / 15 / 20 m; JUMA PA1000+ Amplifier (Rowaves)
Satellite Station: 90 cm Dish; Yaesu FTX-1; QO-100
Ground station FD (DxPatrol); SDR Console (RX)
QSL/Confirmations: QSL Policy: Direct only (see QRZ.com); QRZ Logbook. Your confirmations via QRZ.com are greatly appreciated. Watch the slideshow on QRZ.com

Contact

yl.beam news: Editor Eda (Heather)
zs6ye.yl@gmail.com

Newsletters can be found at <https://warc-anode.blogspot.com/>; the Italian Radio Amateurs Union: QTC U.R.I. www.unionradio.it/qtc-la-rivista-della-unione-radioamatori-italiani/, the West of Scotland Amateur Radio Society <https://wosars.club/category/yl-news/>, the YLs-Amateur Radio Ladies-Portugal www.facebook.com/CT2ISX and Ham YL www.facebook.com/ham.yls

The RaDAR Rally

Eddie Leighton, ZS6BNE

The RaDAR Rally was developed by Greg Lane, N4KGL. Greg, an experienced communicator, designed the rally rules enhancing the basic requirements of the RaDAR Challenge from years gone by.

RaDAR Rally Rules

Objective: use your amateur radio knowledge, portable equipment and physical skills to challenge yourself during an unforgettable four-hour experience. The four-hour duration creates an

urgency that demands optimized equipment and operating strategies.

When: the first Saturday of April and November. Choose four hours during the UTC day. The following Sunday is a backup date if Saturday is unfavourable for you.

Where: you may choose any outdoor venue where you can legally and safely operate. Parks are a natural choice. Make it as scenic and exciting as you can. You may combine RaDAR Rally with Parks

(Continued on page 62)

(The RaDAR Rally from page 61)

on the Air, POTA or Summits on the Air, SOTA. (or even Islands on the Air (IOTA) Ed.)

Activity: arrive at the first deployment, make five contacts, move to the next deployment and repeat as quickly as possible for four hours.

Movement: RaDAR deployments are at fixed locations. Between deployments, movement may be via walking or canoeing for at least one kilometre, bicycling for at least two kilometres, or using a motorised vehicle for at least six kilometres. The wheelchair or mobility scooter distance is 500 metres. Combine modes of movement as you desire. You can reuse a deployment location. The last deployment must have at least one contact. A RaDAR operator may have team mates assist in all aspects of RaDAR to increase the fun.

Preparation: research your venue, rig, antennas and conveyances to optimise your score. Use practice deployments to build your skills and evaluate your gear. Remember to pack items for your comfort and safety.

Bands and Modes: all amateur bands and modes are allowed except terrestrial repeaters. You may work a station on multiple bands/modes at a deployment location and work them again on another deployment. You can use any means to spot your activity.

Contact Exchange: the exchange will vary with these situations:

1. Calling CQ RaDAR: Exchange signal report and location.
2. Answering a CQ: Use their activity exchange.
3. RaDAR-to-RaDAR: Exchange signal report and an eight-digit grid square (3 QSO points)

Chasers: RaDAR operators appreciate amateur friends who help them get those five contacts required to move. Since RaDAR ops bounce between operating and moving, often with low power and compromise antennas, they are like rare DX. Please chase them. The QSO will make their day and yours.

Scoring: the QSO points earned are - three for RaDAR-to-RADAR contacts, two for POTA or SOTA contacts and one for all other stations. Make five or more contacts at deployment, but only five counts for QSO points. The final score equals the

total QSO points times the number of deployments plus bonus points.

FT Mode Ops: Since the FT exchange is limited, you will not know if the other station is POTA/SOTA or RaDAR. However, you may count the contact as POTA/SOTA or RaDAR if you can determine their status from spotting information, their logs, or by directly contacting the operator.

Bonus Points: three bonus points for each non-motorised transition, two points per deployment when all contacts are QRP, equal to five watts or less on CW and ten watts or less for other modes. The first intercontinental RaDAR-to-RaDAR contact is six bonus points. RaDAR-to-RaDAR or Chaser-to-RaDAR contacts with a matching QSL in The COOL log earn one bonus point for each. See the Logging section below.

Registration: registration starts one month before the event. E-mail the RaDAR POC your registration info. The POC will post a roster on the RaDAR Rally website at <https://radarrally.blogspot.com/>.

Registration information includes: Name, Call, Day (Saturday or Sunday), Venue, Start UTC, Conveyances, Bands, Modes, QRP (Y or N) and Spotting method (optional).

Reporting: E-mail your summary information to the RaDAR POC within seven days of the event. The RaDAR POC will post them on the RaDAR website <https://radarrally.blogspot.com/> and the RaDAR groups.io. The summary information includes: Name, Call, Day (Saturday or Sunday), Venue, Start UTC, Conveyances, Bands, Modes, QRP (Y or N), R-to-R QSOs, Pota/SOTA QSOs, other QSOs, Deployments, Bonus Points, Eight-digit grid squares for your deployments and the link to your detailed report, photos, or videos

Logging: A log is not mandatory. It is highly encouraged to use the "COOL logger/Spotter managed by Eddie, ZS6BNE. It can be updated in real-time or after the rally. The log will calculate your score and bonuses. The main page is at www.radarops.co.za

Also see https://radarops.co.za/radarsport/rally_report.php an online RaDAR Rally Evaluator.

(The RaDAR Rally from page 62)

Awards: There are no awards at this time. The RaDAR Rally is more of a personal challenge than a competition. Use your score to track your improvement.



The RaDAR Rally dialogue is available on The COOL. Available to registered COOL users.

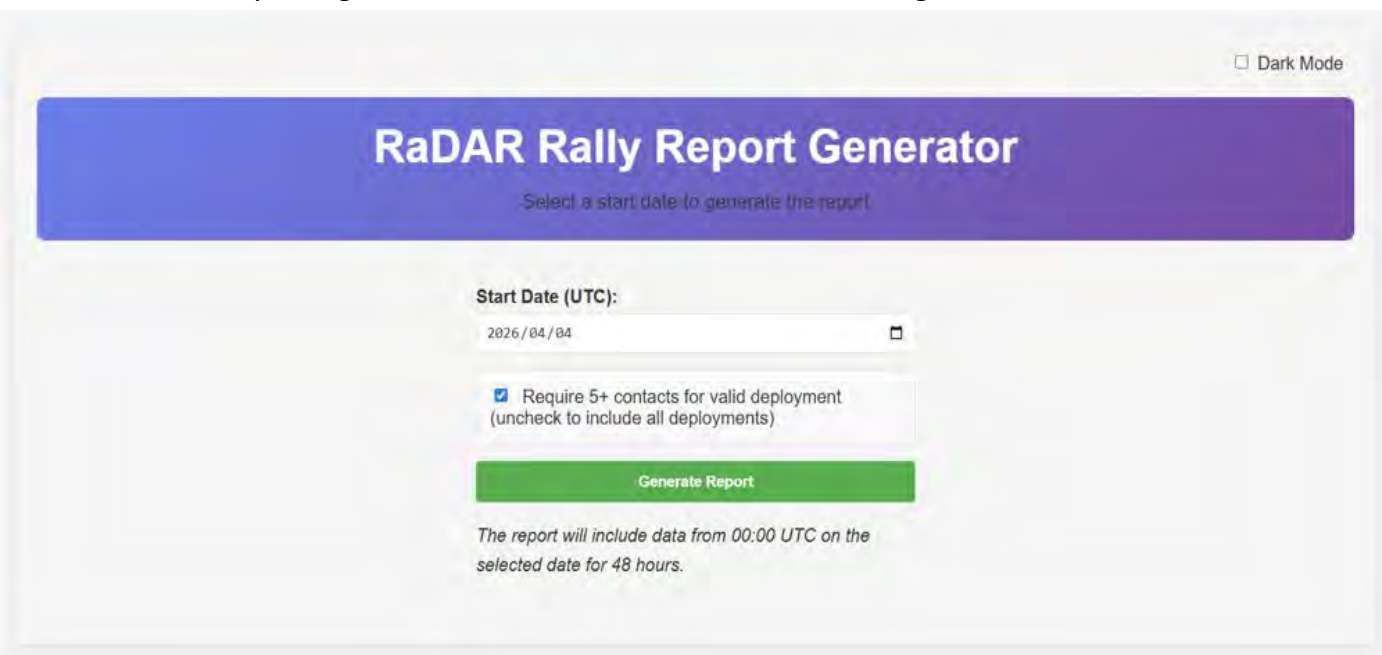

Within SECONDS the entire RaDAR Rally can be evaluated online. All participants logging their RaDAR Rally QSOs on The COOL. The COOL was originally developed for this purpose!

(Continued on page 64)

(The RaDAR Rally from page 63)

The following results are true extracts from the recent RaDAR Rally.

N4KGL

Total Entries: 25

Summary:

Valid Deployments: 5

Total Contacts: 25

Total QSO Points (before multiplier): 28

Basic Score: 28 × 5 = 140

Bonus Points Breakdown:

RaDAR-to-RaDAR: 0

Non-motorized Transitions (4 × 3): 12

QRP Deployments (0 × 2): 0

Intercontinental RaDAR-to-RaDAR: 0

QSL Matches: 0

Total Bonus Points: 12

Final Score: 152

Deployment: 4 (5 contacts) | Transport: On foot | Bonus: 3 RaDAR-to-RaDAR: 0

| # | Date/Time | Other Callsign | Frequency | Mode | Power | Category | QSO Points | Grid | Other Grid | QSL |
|---|---------------------|----------------|-----------|------|-------|------------|------------|----------|------------|-----|
| 1 | 2026-04-04 17:53:00 | KR4IIB | 14.0640 | CW | QRO | R to POTA | 2 | US-12965 | US-2755 | |
| 2 | 2026-04-04 17:54:00 | AA4HI | 14.0640 | CW | 5W | R to Other | 1 | AL | NC | |
| 3 | 2026-04-04 17:55:00 | KJ4JSF | 14.0640 | CW | 5W | R to Other | 1 | AL | VA | |
| 4 | 2026-04-04 17:57:00 | WB3DDJ | 14.0640 | CW | 5W | R to Other | 1 | AL | PA | |
| 5 | 2026-04-04 17:59:00 | W2TAO | 14.0640 | CW | 5W | R to Other | 1 | AL | NY | |

Deployment: 5 (5 contacts) | Transport: On foot | Bonus: 3 RaDAR-to-RaDAR: 0

| # | Date/Time | Other Callsign | Frequency | Mode | Power | Category | QSO Points | Grid | Other Grid | QSL |
|---|---------------------|----------------|-----------|------|-------|------------|------------|----------|------------|-----|
| 1 | 2026-04-04 18:40:00 | KY4REX | 14.3170 | SSB | 20W | R to Other | 1 | AL | KY | |
| 2 | 2026-04-04 18:42:00 | K0LBR | 14.3170 | SSB | 20W | R to POTA | 2 | US-12965 | US-6474 | |
| 3 | 2026-04-04 18:43:00 | AA5EY | 14.3170 | SSB | 20W | R to Other | 1 | AL | TX | |
| 4 | 2026-04-04 18:43:00 | WB3HPE | 14.3170 | SSB | 20W | R to Other | 1 | AL | VA | |
| 5 | 2026-04-04 18:44:00 | AC3KT | 14.3170 | SSB | 20W | R to POTA | 2 | US-12965 | US-1569 | |

The RaDAR Rally is a special activity supported internationally. It is not a specific South African activity, nor does it feature in the contest manual. RaDAR operators in South Africa are few and far between but if you are like minded, consider taking part. Log your RaDAR Rally logs on The COOL, use the COOL daily, it is after all a South African development!

BOMBASTIK

AMATEUR RADIO ACCESSORIES

**Bombastik Crew Offer Great
Customer Service and Quality
Above All.**

**COUNTRY
WIDE
SHIPPING**

OUR SERVICE:

- ✓ **Antennas:** See our high quality hand crafted antennas and accessories.
- ✓ **Radios:** Premium-quality Chinese radios. No cheap knockoffs—only high-spec, unbeatable value!
- ✓ **Accessories:** A wide range of top-quality equipment that you'll be proud to own.



082 785 7763



<https://www.bombastik.co.za>

RONNIE'S RADIO SHACK

Reliable Communications when you need it most

www.ronniesradioshack.co.za



Icom IC-7300 HF & 6m



Alinco DR-735T Dual Band 2m/70cm FM only



Icom IC-9700 2m/70cm/23cm Allmode Radio



Icom IC-7100 HF/6m/2m and 70cm Allmode



Wouxon KG-UVAD-Plus
Dual Band portable



Yaesu FT-4X Dual band Portable



Vertex Standard
VX-1400 HF 100w



Vertex Standard
VX-1700 HF 100w

Shop Online at: www.radiosshack.online

Home

Contents



A Report on the 2026 SARL National Convention

Dennis Green, ZS4BS, SARL Secretary - as sent to Members on Sunday 3 May 2026

3 May 2026 ZS. The Treasurers Report can also be found on this webpage.

The 2026 SARL National Convention

The 2026 SARL National Convention was held over the weekend of 1 to 3 May 2026 at the Willows Resort and Conference Centre in Port Elizabeth and the Port Elizabeth Amateur Radio Society were the hosts for the weekend.

The Convention began on Friday evening 1 May with a function at the Boma at the Willows Resort, known in Afrikaans as “n ken mekaar.” An eyeball QSO with a braai – with wine and gin & tonic sponsored by Meridian Wine Merchants and Fitch and Leedes.

Saturday 2 May was a beautiful day, weather wise. The partners programme to SANCCOB had unfortunately to be cancelled – some or other cycling event with a ‘marshal’ who would not allow the ladies through to SANCCOB – the cyclists were nowhere to be seen. The ladies then went to plan B and enjoyed coffee and eats at a venue near Sardinia Bay.

The 2026 AGM was opened at 09:00 on Saturday 2 May, by Nico, ZS6QL. This took place in the Conference Centre at the Willows. Kevern, ZR2BK welcomed all the delegates to Port Elizabeth.

Of the 1 487 SARL Members allowed to vote, only 49 members attended in person, with 251 members providing proxies = 300 votes or 20,2%. (The 2024 AGM in Cape Town was 19%, the 2025 AGM in Pretoria was 16,03%.)

The oldest member present at the AGM is Allan Whitehead, ZS2R, who is 79 years young and the youngest is Chloe Zaayman, ZR1CZ who is 16 years young. The average age at the AGM is 56 years.

The oldest member who submitted a proxy is Smitty Smit, ZS1AK, who is 91 years young and the youngest member to submit a proxy is Ju'ah Lorenz, who is 13 years young.

Nico, ZS6QL, presented the President's Report, followed by Corrie, ZS6CDB, presenting the Treasurer's Report. The 2025/26 SARL Annual report was sent out by e-mail on Friday evening 1 May, it is available at <https://mysarl.org.za/sarl-agm-2026/> as well as the May 2026 issue of Radio

Motions

Motion 2026-01. Receive the Annual Financial Statements for the year ending 30 June 2025.

Motion 2026-02. Receive the proposed budget for year ending 30 June 2027.

Motion 2026-03. To receive and ratify the proposed subscriptions for year 1 July 2026 to 30 June 2027.

Motion 2026-04. Appointment of Beans Accounting Services as Reviewers until the 2027 AGM.

Motion 2026-05. Changes to the Constitution with respect to the auditing function.

Motion 2026-06. Changes to the Constitution with respect to Governance.

These motions were unanimously accepted with no votes against or abstentions.

Motion 2026-07. Amendment of SARL Fees for those from 60 to 65 Years was not accepted with 219 votes against and 3 abstentions.

Council

The following Councillors are at the end of their two-year term of office which ends at the 2026 SARL AGM - Dave Higgs, ZS2DH; Karel Bezuidenhout, ZR6K; Chris Turner, ZS6GM; Rassie Erasmus, ZS1YT and Dennis Green, ZS4BS.

Dave Higgs, ZS2DH and Karel Bezuidenhout, ZR6K indicated that they will not stand again.

By 31 January 2026, nominations, signed by the nominee, proposer and seconder, were received for Chris Turner, ZS6GM; Rassie Erasmus, ZS1YT; Dennis Green, ZS4BS; Gary Immelman, ZS6YI; Brian Jacobs, ZS6YZ; Noel Hammond, ZR6DX; Kevern Burger, ZR2BK and Danie Schnetler, ZS6DPS.

As there are five vacancies and eight nominations, in terms of Rule 16.6 all SARL Members who are eligible to vote had to vote for five of the eight candidates. Voting opened at 00:01 CAT on Thursday 2 April and closed at 23:59 CAT on Friday 24 April 2026. Of the 1 480 SARL members allowed to vote, 343 members or 23,18%

(Continued on page 68)

(National Convention Report from page 67)

cast their vote. (1 487 vs 1 480? New members who joined after voting opened.)

The following nominees received the most votes - Dennis Green, ZS4BS; Rassie Erasmus, ZS1YT; Gary Immelman, ZS6YI; Noel Hammond, ZR6DX and Chris Turner, ZS6GM.

The Council is thus - Nico van Rensburg, ZS6QL; Corrie de Beer, ZS6CDB; Karel Bezuidenhout, ZS6WN; Guy Eales, ZS6GUY; Phillip van Tonder, ZS6PVT; Dennis Green, ZS4BS; Rassie Erasmus, ZS1YT; Gary Immelman, ZS6YI; Noel Hammond, ZR6DX and Chris Turner, ZS6GM.

The SARL 100 Commemorative Book

The first part of the SARL 100 Book has been printed and is available for purchase. The Book costs R150 (excluding the courier) and must be ordered from Kelley at the National Amateur Radio Centre. We encourage Clubs to place a bulk order and save on the courier costs.

The next part will focus on the YLs. The Editorial team is waiting for Clubs to submit their Club history.

The 2027 SARL National convention

The Centurion ARC have indicated that they want to host the 2027 SARL National Convention. Between Centurion and the Council, a date will be determined.

Closure

The meeting closed at 12:00 CAT and each Member attending received PEARS goodie box with an amateur radio sticker, keyring, pen and an insulated mug!

The First Council Meeting

In terms of Rule 16.15, the retiring SARL Secretary chaired the first Council after the closing of the AGM. The Councillors elected Guy Eales, ZS6GUY as President, Phillip van Tonder, ZS6PVT as Vice President, Corrie de Beer, ZS6CDB as Treasurer and Dennis Green, ZS4BS as Secretary.

The SARL Awards Dinner

The SARL Awards Dinner was well attended at the Willows Conference Centre. Dennis, ZS4BS, Kevern, ZR2BK and Nico, ZS6QL welcomed all to the

dinner.

Nico, ZS6QL delivered his address as retiring President during which he handed over Long Service Awards to Rassie, ZS1YT and Dennis, ZS4BS for more than 26 years' service on Council.

He then handed over the Chain of Office to incoming President, Guy, ZS6GUY. Guy and Phillip, ZS6PVT address the dinner guests.

Following the dinner, the various awards and trophies were handed over. The complete list will be published in the June 2025 issue of Radio ZS (page 9,10 and 11.).

Honorary Life Membership was awarded to Sid Tyler, ZS5AYC, while Jan Botha, ZS4JAN, was inducted into the SARL Hall of Fame.

The Willie Wilson Gold Badge was handed to Adele Tyler, ZS5APT; Michael Taylor, ZS1MJT; Christo Kriek, ZR6LJK; Gert Botha, ZS6GC and Keith Barker, ZS6HI

The Koos and Annie van der Merwe Platinum Award was given to Theunis Potgieter, ZS2EC and Dave Higgs, ZS2DH

The Koos and Annie van der Merwe Gold Award was given to Tony Allen, ZR2TX; Chris Scarr, ZS2AAW; Andrew Gray, ZS2G; Glen Cummings, ZS2GV; Jaco Louis Kruger, ZS6JLK and Devon Person, ZS6DEV.



The May RAE on the West Coast

Roy Walsh, ZS1YR

The West Coast Amateur Radio Club had their official first RAE exam on Saturday 16 May. Previous exams were under other Clubs. In the beginning it was under Bo-Karoo Amateur Radio Club and then the Northern Cape Amateur Radio Club. Now the Club is affiliated to the SARL and we have the exam centre registered. There were 2 students who wrote the exam - Deon Cross ZS1DCE and Mike Hartley ZS1MIK, both passed and achieved A's. Deon is now ZS1DCE and Mike is ZS1MIK. Welcome to the Club and the best hobby ever.



The AGM on 2 May

Thanks to Kevern, ZR2BK and Eugenie Burger for the photos



"Don't they know they have to be here 7 minutes before the start!" The Sergeant-Major checking his watch

The goodie boxes





Corrie, ZS6CDB presenting the financials



The beautiful ladies ready for their excursion (that, because of a bicycle race, could not take place.)



Tea time goodies



Nico, ZS6QL presenting the SARL Annual Report



Rulhof, ZS4RM talking to the meeting about Youth in Amateur Radio



Brian, ZS6YZ handing over a copy of the SARL 100 Commemorative Book to Nico, ZS6QL

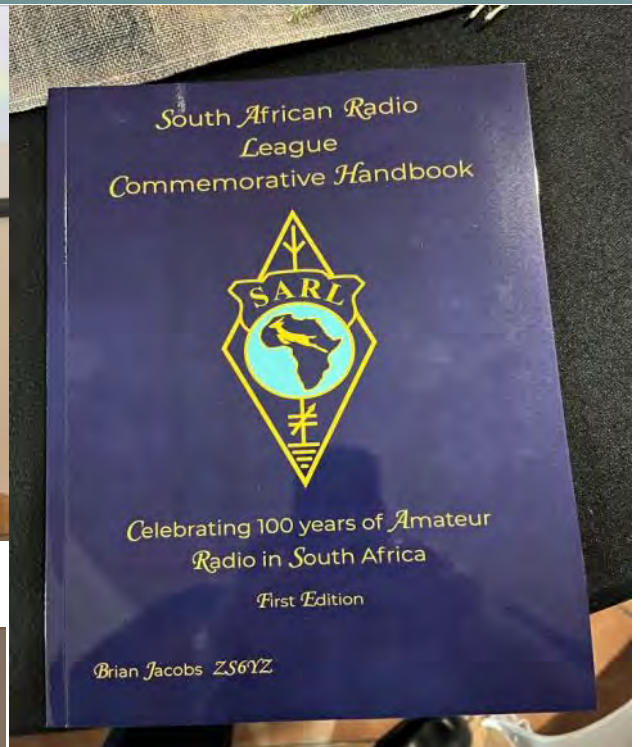



The first meeting of the new SARL Council. Rule 16.15 of the Constitution and Rules states, "The person who held office as League Secretary prior to the last AGM, or failing him any member of Council, shall within thirty (30) days after such AGM, convene the first meeting of the incoming Council." So for about 15 minutes, ZS4BS was the Main Man What Counts!

Seen below is Guy, ZS6GUY, the new SARL President; Dennis, ZS4BS, the SARL Secretary (again!); Nico, ZS6QL; Corrie, ZS6CDB, the SARL Treasurer; Phillip, ZS6PVT, the new Vice-President; Karel, ZS6WN; Gary, ZS6YI and Rassie, ZS1YT. Chris, ZS6GM and Noel, ZR6DX had made apologies for the weekend.



The Lucky Draw HF Radio (donated by Dennis, ZS4BS) - won by Karel, ZS6WN

The Slettnes Lighthouse

Woody Collett, ZS3WL, the Lighthouse Keeper

We have travelled all the way from sunny California to the far northern parts of the European Continent and for those of you who followed the Bouvet Island 3Y0K DXpedition, will recognize the flag above as that of Norway. Yes, we are at the northernmost tip of Norway bordering the Barents Sea and near the small town of Gamvik and it is just north of the town that we find Slettnes Lighthouse, which has the distinction of being the most northerly lighthouse on mainland Europe. However, the most northerly lighthouse in the northern hemisphere is located on the Island of Svalbard, near the settlement of Longyearben some 200 nm/370 km further northwards.

Slettnes Lighthouse is one of the three lighthouses in the Nordkapp area and the easternmost of the three. It is the northernmost lighthouse on the mainland of Scandinavia.

Gamvik is located along the northern shore of the Nordkapp Peninsula bordering the Barents Sea and occupation goes back as far as the 1850's. The Slettnes lighthouse is situated about 3 kilometres north of Gamvik village. The area also is a breeding ground for important bird species and is also home to the second largest colony of parasitic jaegers, otherwise known as the Arctic Skua. The remains of the old Gamvik Airport and ruins of WW2



(Continued on page 76)



(Lighthouses from page 75)

fortifications also lie north of the village.

Historically the village was accessible by boat only and due to poor harbour conditions, the steamers operated by Hurtigruten had to anchor a short distance offshore and smaller boats were used to ferry people and goods ashore.

During 1970 the airport at Gamvik was rebuilt and the Norwegian County Road 888 was built to connect Gamvik to settlements further south, including the capital of Norway some 2 040 kilometres away.

Slettnes Lighthouse was badly damaged by the German Forces during WW2, but painstaking restoration work was done after the end of the war, with the designers being architects Munthe-Kaas and Blakstad with restoration being completed during 1948. It is managed today by Gamvik Municipality as a tourist centre, with overnight accommodation available at the buildings. It was listed as a National Heritage site in 1998.

During the months of summer, you can join guided tours of the lighthouse tower and afterwards enjoy coffee and a waffle in the small café on site.

The Lighthouse

The Lighthouse was constructed between 1903 to 1905. The tower itself was of cast iron and 39 meters tall and is fully red in colour with two white horizontal bands. The lighthouse is lit from about 12 August to 24 April each year, as being located so



far north it is not needed to be lit during summer months because of the perpetual “midnight sun.”

During 1922, the lighthouse was equipped with a foghorn and a siren, which sounded every 30 seconds and was audible at 6 nautical miles or 11 km. The foghorn was discontinued during 1985.



Midsummer night photo taken around midnight. (I remember in May 2013, Carina and I walking in the streets of Reykjavik, Iceland at midnight—no streetlights on, because the Sun was just above the horizon. Ed.)



Caribou and Arctic Foxes are found in the area

(Lighthouses from page 76)

General

For those of you who are not afraid of the cold weather, this is a good place to visit during the summer months and then you can say that you have been inside the Arctic Circle. Be sure even during the summer to take some cold weather gear with you as the weather can turn very quickly. If you visit during the winter months you will also maybe be able to see the Famous Aurora Borealis (Northern Lights). Winter temperatures of minus 30 C are possible.

Now if you are really adventurous, then go visit Svalbard Island, another 200 nm further north in the Arctic Ocean... where temperatures around minus 40 C in winter are the order of the day. Its largest town is Longyearben where you will find the World Seed Depository. Enjoy your travels

The Technical Stuff

Constructed: 1905

Construction: Cast Iron Tower

Foundations: Concrete base

Height: 39 meters



Design shape: Cylindrical tower with balcony and lantern

Day markings: Red tower with two horizontal white bands.

Heritage status: Recognised as a cultural heritage building

Light: first lit on 15 September 1905

Intensity: 1 706 000 candelas

Range: 20,3 nautical miles or 32,6 km

Flash pattern: 1 x white flash every 20 seconds.

Co-ordinates: 71° 05' 22" N 28° 13' 5" E

Grid square: KQ41CC

Norwegian Lighthouse number: 956500

ILLW lighthouse number: NO0008

ARHLS number: NOR215

Credits

Ibiblio/Lighthouses/University of S Carolina, Google Earth, Wikipedia, Norwegian Tourism.



The Museum Column

The Radios that Started and Ended World War II in the Pacific

Hiroki Kato, AH6CY first published in QST, April 2016

An examination of the radios used during the attack on Pearl Harbor and the bombing of Hiroshima.

One of the most iconic radio messages transmitted in modern history is “Tora, tora, tora,” sent from a Japanese bomber in the Hawaiian skies to the waiting aircraft carrier in the northern Pacific on the morning of 7 December 1941. It signalled the successful surprise attack on the American Pacific fleet in Pearl Harbor. President Roosevelt declared war against the Empire of Japan the following day.

On the morning of 6 August 1945, the *Enola Gay*, a B-29 bomber, transmitted a message from the skies over Hiroshima to the American base in Tinian in the south Pacific, announcing the successful dropping of the world’s first atomic bomb. Nine days later Japan surrendered, ending World War II.

I was born in Hiroshima a month after the Pearl Harbor attack. I was three and half years old and lived with my family 20 miles/32 km from ground zero on that day in 1945. Twelve years later I entered high school. The school building, located less than 2 miles/3,2 km from where the bomb was dropped, had been rebuilt. I got my first amateur license in the same year and moved to the US after college in 1966. For all these years, I have wondered about the radios used in those two historic missions.

American Military Surplus

I began my search for those radios in earnest in 2000, when I retired. Finding information on wartime American radio equipment and acquiring radios of the same models that were aboard the *Enola Gay* turned out to be relatively easy. Information on US military radios manufactured during World War II has long been declassified, including schematics, manuals and repair instructions. The *Enola Gay* itself was fully restored, including the original radios and is on permanent display in the Smithsonian National Air and Space Museum’s Steven F. Udvar-Hazy Centre in Virginia (see Figure 1).¹

Moreover, most of the military radios that were used in battlefields and in the air and then repatriated to US soil after the war’s end (as well as those still stored in warehouses) were sold in the postwar open market as military surplus. Many American amateurs from the late 1940s through the 1960s got their start by acquiring inexpensive surplus gear and converting it for use on the amateur bands. The advent of the online market in the 1990s also made it easy to acquire radios from that era. Even today, over 70 years after the war ended, there is still an active market for World War II surplus American military radios.

Rare Japanese Radios

Researching and searching for Japanese military radios of the same era turned out to be a much



Figure 1. The author and the *Enola Gay*. (Continued on page 79)

(The Museum Column from page 78)

more trying proposition. General Douglas MacArthur's Allied Forces occupation in Japan, as well as the Japanese government, were slow and reluctant in de-classifying the wartime information. Also, under MacArthur's orders, all Japanese war materials, including any communication equipment and their associated manuals and schematics, were destroyed in the postwar occupation period, with the exception of a small number of radios permitted for use by police and government agencies to augment the landline telephone system, which had been heavily damaged by US bombings during the war. Thus, the Japanese military radios that survived and that can be seen today are those small exceptions, those captured in the battleground and studied by the American military or brought back by American GIs as souvenirs. There was a US government programme that encouraged GIs to rip off and bring home or mail in the labels or plates attached to any captured radios, for intelligence-gathering purposes. The plates often listed model names, serial numbers, manufacturers and locations and years of manufacture.

There are only two sizable World War II Japanese military radio collections in Japan that I am aware of, both of which are in private museums and their collections are not very extensive, by usual museum standards.² Quite unexpectedly, in 2012, I found and was able to acquire a transmitter that was the same as that on board the command aircraft (a three-seater bomber) that attacked Pearl Harbor and transmitted the "Tora, tora, tora" message. I was not able to find out how exactly this particular transmitter ended up in someone's garage in California. The only thing the owner, who sold it to me over the phone, knew was that it was a Japanese military radio and he had acquired it from a Silent Key many years before. I learned about the model name, manufacturing year and so on only after I brought it home.

The "Tora, Tora, Tora" Transmitter

The transmitter on board the three-seater Japanese bomber was Model 96 "Ku" Mark 3 Version 2 (see Figure 2) and was manufactured by Nippon Denki Co. The specs are as follows:
Range: 1 300 km (800 miles)



Figure 2. A front view of the Model 96 "Ku."

Figure 3. The Model 96 schematic



Frequencies: 300 – 500 kHz;

5 000 – 10 000 kHz

Mode: CW only Power: 150 W

Frequency Control: Crystal and VFO Final Power Tube: UV816D

The transmitter-receiver pair on board was

(The Museum Column from page 79)

designed for air-to-air, air-to-ground and air-to-ship application. There is no record that these radios were ever used on the ground. The transmitter was powered by a dynamotor to supply high plate voltage from the aircraft's 12 V DC supply, the standard voltage for Japanese military aircrafts at the time. This particular model, manufactured in 1941, is a revised model of the transmitter originally produced in 1936 (see Figure 3). The original model did not have the LF band.

The Enola Gay Transmitter

In general, the radios used in the American military were superior in performance and features to those used by the Japanese military in World War II. In fact, some of the radios manufactured for the Japanese military were copies of American radios, such as National receivers.

The transmitter on board the *Enola Gay*, model ART-13 (see Figure 4), was designed in 1940, manufactured by Collins and had the following specs:

Range: 1 500 miles / 2 414 km

Frequencies: 2 000 kHz – 18 100 kHz (LF band module option)

Modes: CW, Modulated CW, AM Power: 100 W

Frequency Control: VFO (Crystal control unit option)

Final Power Tube: 813

The ART-13 was paired with the BC-348 receiver and was powered by a dynamotor to

supply the high plate voltage from the aircraft's 28 V DC source; the typical voltage used in American aircraft. The transmitter has 10 frequency pre-programmable VFOs, which are extremely stable. No other transmitters of the era had this feature.

Radio Messages from Pearl Harbor

Hundreds of popular Hollywood movies, books and articles about Pearl Harbor depict a scene where Commander Michio Fuchida broke radio silence by yelling "Tora, tora, tora" into his microphone to commence the attack. This narrative, however, is not historically accurate. Amateurs would immediately know from the specs above that the radio was not capable of transmitting voice messages using the AM or SSB mode, but only codes in CW. What really happened, radio-wise, is this: at 7:49 AM on 7 December 1941, Fuchida ordered his radioman, Norinobu Mizuki, to send in the Japanese Morse code, "To, to, to" (pronounced "toh, toh, toh") — the signal to begin the attack. Four minutes later, at 7:53 AM, he ordered Mizuki to send "Tora, tora, tora," the coded message indicating to the waiting flagship *Akagi* 320 miles/514 km away that the surprise attack was successful.

The Japanese Morse code is not an alphabetic code system in the sense that each code represents a vowel or consonant sound as in English, but is, technically speaking, a syllabogram system. Thus, "to" (written in a single Japanese kana symbol と) represents one syllable and has its own code "...". and "tora, tora, tora" (とら,とら,とら) is sent in six Japanese CW codes: "...".

Code Sent from Hiroshima

Like the Pearl Harbor attack, the Hiroshima bombing has been the subject of hundreds of movies, books and articles, often repeating the same inaccuracies for the sake of dramatization. One common image is that of the *Enola Gay* sending a message immediately after the bombing: "Mission successful, we are coming home." It is widely believed that this message was sent to the waiting team in Washington and then relayed to President Truman in Potsdam,

(Continued on page 81)



Figure 4. Top view of the ART-13

(The Museum Column from page 80)

Germany, where he had been meeting with Stalin and Churchill to discuss postwar arrangements.

What really happened was considerably more complex and nuanced. The B-29 bomber was normally equipped with one ART-13 long-distance "liaison" transmitter, designed to communicate up to 1 500 miles. But the *Enola Gay* was outfitted with two ART-13s for this particular mission. One was used to transmit a steady Modulated CW tone when the final bomb run began. When the tone ceased, it meant that the bomb was released. That occurred at 8:15 AM, 6 August 1945 Japan time, 45 seconds after the bomb run had begun.

The first message, after the successful bombing was ascertained by the crew on board, was transmitted 14 minutes later to the Tinian base in CW, by the radioman, Richard Nelson, by order of Captain William S. Parsons, the atomic bomb expert specially assigned to this mission by the Manhattan Project. The only crew members on board the *Enola Gay* who had known the true and entire nature of the mission all along were Parsons and Captain Paul Tibbets. The transmitted message was directed to Brigadier General Thomas F. Farrell, waiting in Tinian. Farrell was a personal representative of General Leslie R. Groves, the Director of the Manhattan Project, who was waiting in Washington.

The actual CW codes sent were "A1269" - decoded, it read "Clearcut, successful in all respects; visible effects greater than Trinity; Hiroshima primary target; conditions normal in airplane following delivery, proceeding to regular base." "Trinity" was the codename of the first successful test explosion of an atomic bomb in Alamogordo, New Mexico, in July 1945. The coded message table had been devised only 2 days before the Hiroshima mission, strictly between Farrell and Parsons. No one else, including the radioman

Nelson and Captain Tibbets, knew what each letter or number represented. President Truman was already crossing the Atlantic on his way back from Potsdam by the time he actually received the detailed message from Washington 16 hours later, but the announcement of the successful bombing had already been made to the world, due to a previous arrangement

Notes

¹ In 2011, I met Mike Hanz, KC4TOS, who helped restore the *Enola Gay* radios. From him I learned of the authenticity of the restored radios, down to the use of original wires of World War II vintage. An article on my own *Enola Gay* radio restoration project appeared in the August 2011 issue of *Electric Radio*.

² These collections can be found at the Yokohama World War II Japanese Military Radio Museum (www.yokohamaradiomuseum.com/index.html) and at the Hiroshima Wartime Communications Technology Museum (<http://minouta17.web.fc2.com/>).

All photos are courtesy of the author.

Hiroki Kato, AH6CY, was born in Hiroshima and was first licensed as JA4AAO when he was in high school. After college, he came to the US to pursue graduate studies. Dr Kato taught political science and linguistics at several universities, including the University of Hawaii, Harvard and Northwestern. He got his current call sign when he lived in Honolulu. He later worked for early Silicon Valley startups, retiring in 2000. He enjoys QRP portable and QRO remote operations, having been on the air from many states and countries. When at home in California, he collects and restores boat anchor radios, focusing on World War II-era radios. He can be reached via ah6cy@arrl.net.

HF Update

Dennis Green, ZS3I

All Africa Award

Kenya, 5Z. Paul MM0ZBH is active from Murang'a 'holiday-style' until 15 June. Operation so far has been on 10 metre digital and 20 metre CW and SSB. QSL via LoTW.

Morocco, CN. Pascal, F8NQV is active as

CN2NQV until 11 July with activity from Sidi Rahal Chatai on 40, 20, 17, 15 and 10 metres.

Namibia, V5. Eric, V5/N7XOB is travelling for a month (mid-May to mid-June) and will be active from various locations and grids. QSL via LoTW.

(Continued on page 82)

(The Museum Column from page 81)

Tanzania, 5H. Kasimir, DL2SBY will again be operating as 5H1KB between 3 and 12 June. His focus is on 6 metres during his trip. QSL via home call and LoTW.

Tanzania, 5H. With dates not yet certain, Dov, 4Z4DX and Eyal, 4X1RE plan to be active from Tanzania as 5H2DX (CW and SSB) and 5H2RE (SSB) sometime in August or September 2026. They hope to activate different National Parks within the country. Updates to follow.

Tanzania, 5H. Chas, NK8O will once again be operating as 5H3DX between 8 June and 2 July with operation from 30 to 10 metres using CW, SSB and digital. QSL via NK8O, LoTW or OQRS.

Rwanda, 9X. Al, F8FUA will be operating from Kigali as 9X5KM between 4 and 13 June. Operation is 'holiday-style' using CW, SSB and digital. Possible active on low bands depending on the local situation. QSL via home call, LoTW. <https://www.qrz.com/db/9X5KM>

Somalia, 6O. The DX-adventure Team will be active as 6O6X during February 2027. Team leader Max ON5UR mentions, *'On 14 February 2026, our local contact was invited to the Ministry of Information and Communication Technology in Hargeisa, where Minister Jamaal Mohamed Jama personally handed over the official licence. During the DXpedition, we will be active under the call sign 6O6X ("six oscar six x-ray")*.

Although the Belgian government still advises against travel to Somalia, several reliable sources confirm that Somaliland, located in the northwest, is the safest region of the country. The safety of the team is the top priority, which is why we have deliberately chosen to organise our activities in this area. On average, the country receives barely 500 visitors per year.'



A Belgian-Dutch team with Marc, ON4AMX; Patrick, ON4HIL; Max, ON5UR; Karel, ON5TN; Marc, ON6CC; Wim, ON6DX; Franky, ON7RU; Geert, ON7USB; Francis, ON8AZ and Ronald, PA3EWP will be active on HF and perhaps QO-100 and EME. The website under construction.

DR of Congo, 9Q. The Mediterranean DX Club will be active as 9T0MD between 30 September and 11 October. The 9T prefix has never been used before. Operation from 160 to 6 metres using CW, SSB and digital. Also, on QO-100 and EME. <https://www.mdxsupport/9t0md/>

Mozambique, C9. The Czech DXpedition group will be active as C8K between 10 and 19 November. They will be active from 160 to 6 metres using CW, SSB and digital with several stations. Satellite QO-100 also. Club Log livestream, QSL via OQRS or via OK6DJ. <https://www.cdxc.cz/>

Mozambique, C9. The Czech DX Team will be active as C8K during September/October 2026. Operation from 160 to 6 metres and QO-100, RS-44, IO-117 using CW, SSB and digital. Club Log live stream if possible. QSL via OK6DJ OQRS, LoTW.

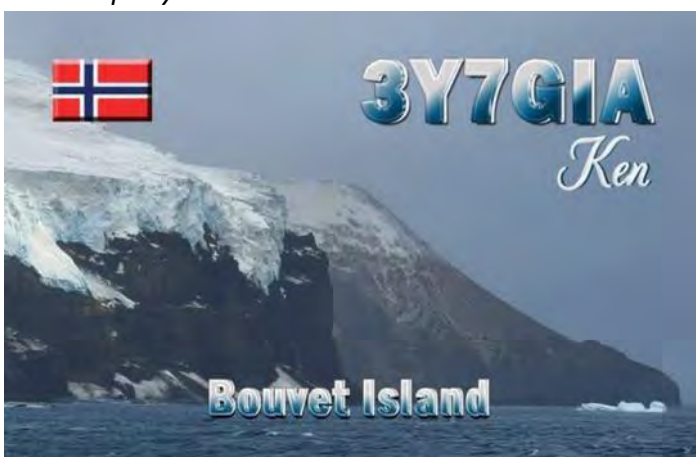

(Continued on page 83)

(HF Update from page 82)

Islands of Africa

Seychelles, S7. Kasimir, DL2SBY will again be active as S79/DL2SBY between 11 and 21 September. Operation from 80 to 6 metres using CW, SSB and digital. QSL via home call or LoTW.

Sao Tome, S9. Francisco, CT7AKS will be active as S9R with EC7R, D2ACE, CT1BOL, D2IM, CT1BZG and CT3MD between 17 and 31 October. They will be active with 3 stations from 160 to 6 metres using CW, SSB and digital. <https://s9r.viacom.ao/>

Cape Verde, D4. Ger, EC1A will be operating as D44EC from 17 to 24 June from Praia. The QTH offers excellent conditions for antennas.

Rodrigues Island, 3B9. Kazu M0CFW will once again be operating as 3B9KW during the CQ WW SSB contest (24 and 25 October) and during the CQ WW CW contest (28 and 29 November). Operation before and after the contest as 3B9/M0CFW between 20 and 28 October and between 22 November and 2 December. QSL via LoTW.

BBC Long Wave Shutdown event

The RSGB and the BBC Amateur Radio Group will be activating four special calls to mark the closure of BBC Long Wave transmissions on 198 kHz (1 500 m) after more than 90 years. The Long Wave transmitters at Droitwich, Worcestershire, Westerglen near Stirling and Burghead overlooking the Moray Firth, will be closed down on 27 June 2026. GB1500M will be active for one week from 21 to 27 June 2026 and may be activated from G, GM, GW, GI, GJ, GD and GU, by RSGB and BBCARG members over the period. GB198LW will be activated by Cray Valley RS (England), GB198END by Moray Firth ARS (Scotland) and GB198KHZ by Stirling and District ARS (Scotland) during the week 21 to 27 June 2026. Full details are on <https://rsgb.org> – search for “BBC Long Wave Shutdown.” A commemorative QSL card will be available for any QSOs or SWL reports via M0OXO OQRS.

Other DX

Juan Fernandez, CE0Z. Felipe, XQ7IR is operating as 3G0Z and XR0Z until mid-June. Operation from 160 to 6 metres using CW, SSB and digital with a focus on the low bands. QSL via M0URX OQRS. <https://www.robinsoncrusoe2026.net/>

Bolivia, CP. Team CP7DX will once again be

active from Tarija from 26 May until 6 June. Operation from 160 to 6 metres using CW, SSB and digital. An entry in the CQ WW WPX CW contest is included. QSL via OQRS or direct via LU1FM.

French Polynesia, FO. Didier, F6BCW is once again active from Tikehau Atoll, Tuamotu as FO/F6BCW until mid-July. He is active on 80 to 6 m using CW and SSB. QSL via LoTW

Market Reef, OJ0. Markus, OH1MN will be active as OJ0MN and Juha OH1LEG as OJ0Z between 30 May and 6 June. Operation on HF, 4 and 6 metres using CW, SSB and digital.

Lord Howe Island, VK9L. A team of 7 operators will be active as VJ2L from 1 to 14 June. This will be a DX Marathon activation ->as many DXCC and zones as possible. Focus from 40 to 10 metres using CW, digital and SSB. For 80 metres they will check on site if possible.

Corsica, TK. Alex, OE5AUH and David, OE5DDJ will be operating as TK/calls from 9 to 22 August. They plan to hike the GR20 trail. Low power station with 10 W.

France, F. Once again the Association des Radio-amateurs de la Sarthe (F6KFI) will operate a special event station for the 24 Hours of Le Mans. Look for TM24H between 30 May and 14 June, with activity on various bands and modes. QSL via F6KFI.

Andaman Island, VU4. Look for team VU4R between 22 and 26 July. Activity on HF using SSB and digital with an entry in the IOTA contest. This is a test in anticipation of the main event between 17 and 30 December alongside the 49th SEANET convention. <https://www.dxindia.in/VU4R>

Bahamas, C6. Eric, K9GY will be operating as C6AYM between 5 and 10 August. Operation from 80 to 6 metres using CW. An entry in the WAE CW



(HF Update from page 83)

contest is included. QSL via LoTW.

Easter Island, CE0. Manu CE3YMR will be operating as 3G0YM in June. He will be active on different HF bands depending on propagation. 'One of the most challenging bands in amateur radio is the 6-metre band, due to its unpredictable behaviour and variable propagation conditions. For this reason, a 3-element Yagi antenna will be incorporated, which will allow us — if conditions permit — to activate this attractive band, highly sought after by radio amateurs.'

Cook Island, E5. Steve, ZL2KE and Steve, ZL4CZ will once again be active as E51CZZ and E51KEE. Between 22 July and 14 August for E51KEE (CW, SSB) and E51CZZ (SSB) between 26 July and 6 August. Activity from Rarotonga. QSL via IK2DUW.

Niue, E6. Gavin, ZL3GAV will be active as E6SP during July. Operation on HF using CW, SSB, SSTV, digital and Satellite. More to follow.

Niue, E6. Tom, KC0W will be operating as E6CW sometime 2026. Operation from 40 to 6 metres using CW only. More to follow.

St Pierre and Miquelon, FP. Matt, W2MJR will be operating as FP/W2MJR from 21 to 26 October. An entry in the CQ WW SSB contest is included with an activity from POTA PM-0025. QSL via LoTW. <https://www.grz.com/db/FP/W2MJR>

St Pierre and Miquelon, FP. Eric, KV1J will once again (18th tour) be active as FP/KV1J, between 27 June and 13 July with an entry in the IARU HF Contest. [FP/KV1J July 2026](https://www.grz.com/db/FP/KV1J/July/2026)

St Martin, FS. John, K9EL will once again be active as FS/K9EL from 10 to 24 June. Activity during his spare time with a focus on 6 metres when it is open, other bands from 40 to 10 metres. Log upload to Club Log and LoTW, QSL via K9EL OQRS.

Solomon island H44, A team with 9A2NA, 9A3MR, 9A3CJY, 9A4WY, 9A7Y and DK8ZZ will be active from Guadalcanal as H49A between 9 and 21 October. Operation on HF and perhaps 6 metres. *'H49A call sign has been issued for our expedition, honouring 15 years of charity work of Croatian Sisters of Charity of St. Vincent de Paul in Buma, Malaita Island, OC-047. Our special call sign itself symbolises ties between Solomon islands and Croatia. Part of amateur donations for the expedition will be redirected to charity work in the*

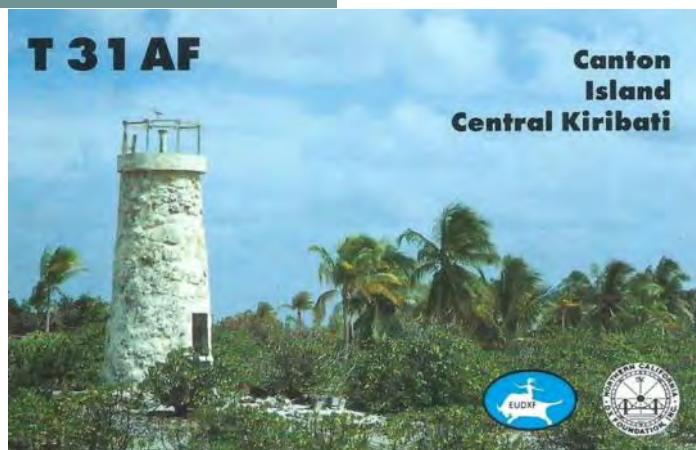

mission.'

Malpelo, HK0. Last active in 2012 (by HKONA who still maintain the second highest ever QSO count for a DXpedition), the Colombian League of Radio Amateurs (HK3LR) and its Board of Directors has announced its main goal – to stage a DXpedition to Malpelo island, SA-007. It is hoped for a February 2027 activity, but this is not yet confirmed. Stay tuned for more info in the coming weeks.

Croatia, 9A. 9A10SOTA is the special call sign celebrating ten years of SOTA Croatia. Look for activity until 30 September 2026. See <https://9aff.wordpress.com/> for information. QSL via LoTW.

Croatia, 9A. To celebrate their 15th anniversary, members of the Croatian Flora Fauna ARC (9A1WFF) are active as 9A44FF and 9A44FF/p until the end of 2026. See <https://www.grz.com/db/9A44FF> for information about the Anniversary Award.

Germany, DL. During 2026, the following special event stations celebrate 100 years of the German aviation company Lufthansa: DA100LH, DL100LH and DK100LH (special DOK 100DLH). QSL via DK5ON (direct or the bureau).

Italy, I. Commemorating the centenary of the Amundsen-Ellsworth-Nobile Trans-polar Flight, members of ARI Colli Albani will operate under the special call sign I10NRG between 12 May and 31 July. The suffix stands for "Norge," the Italian-built airship that achieved the first verified journey to the North Pole (11 to 14 May 1926) and completed the first flight across the polar ice cap from Europe to America. QSL via I0KNQ. A certificate will be available; details will be published on QRZ.

(Continued on page 85)

(HF Update from page 84)

Japan, JA. 8J70JARE is a special call sign celebrating the 70th anniversary of the Japanese Antarctic Research Expedition, which on 29 January 1957 established Syowa Station on East Ongul Island. The special call sign will be in use from various locations across Japan between 22 May 2026 and 29 January 2027. QSOs will be confirmed automatically via the bureau; direct cards should be sent to JG2MLI.

Lithuania, LY. LY100RADIO is the special call sign

celebrating the 100th anniversary since the official beginning of regular radio broadcasting service in Lithuania (12 June 1926). Look for activity from 12 May to 12 July; see <https://www.qrz.com/db/LY100RADIO> for the awards. QSL via LY2QT.

Australia, VK. AX120AAC celebrates the 120th anniversary of the Australian Army Cadets (AAC) during 2026.

Serbia, YU. The special event call sign YU65AEC celebrates the 65th anniversary of the first radio club in Odzaci throughout 2026.

The Surprisingly Long Life of the Vacuum Tube

Brian Potter The ARRL Contest Update for 27 May 2026, <https://www.construction-physics.com/p/the-surprisingly-long-life-of-the>

The last several decades of technological progress have, in large part, been about finding more and more things we can do with semiconductors and the technology for producing them. Microchips have found their way into virtually every car, aircraft, appliance and electronic device. Light-emitting diodes are steadily replacing older, less efficient methods of generating light (such as incandescent bulbs). Solar photovoltaic panels have become the most rapidly deployed energy source in history. Semiconductor lasers have enabled fibre-optic communication. Semiconductor-based charge-coupled devices (CCDs) and CMOS sensors are used for digital imaging. The list goes on.

But decades before the invention of the transistor, another enormous technological ecosystem was built around a device that

manipulated the flow of electrons — the vacuum tube. In the first half of the 20th century, vacuum tube technology found its way into all manner of devices, from radios to TVs to the earliest computers. And like semiconductors today, vacuum tubes had applications far beyond electronic logic — the phenomenon they leveraged could be applied to everything from lighting and displays to video cameras and radars. And while the vacuum tube feels like an ancient technology that has long been superseded, much of the technological edifice still stands.

Origins of the vacuum tube

A vacuum tube is an evacuated tube (often, though not always, made of glass) containing electrodes, between which electrons flow. These tubes, along with various offshoots and technological cousins, were the product of two parallel strands of development.

The first line of descent was via what are known as “gas discharge tubes” — tubes where electricity is discharged through a highly rarefied gas (gas at very low concentration and pressure). Not long after the German scientist Otto von Guericke invented the first vacuum pump in 1650, early scientists began using such pumps to study highly rarefied gasses. It was observed that running

(Continued on page 86)

Triode vacuum tubes, via [Wikipedia](#)



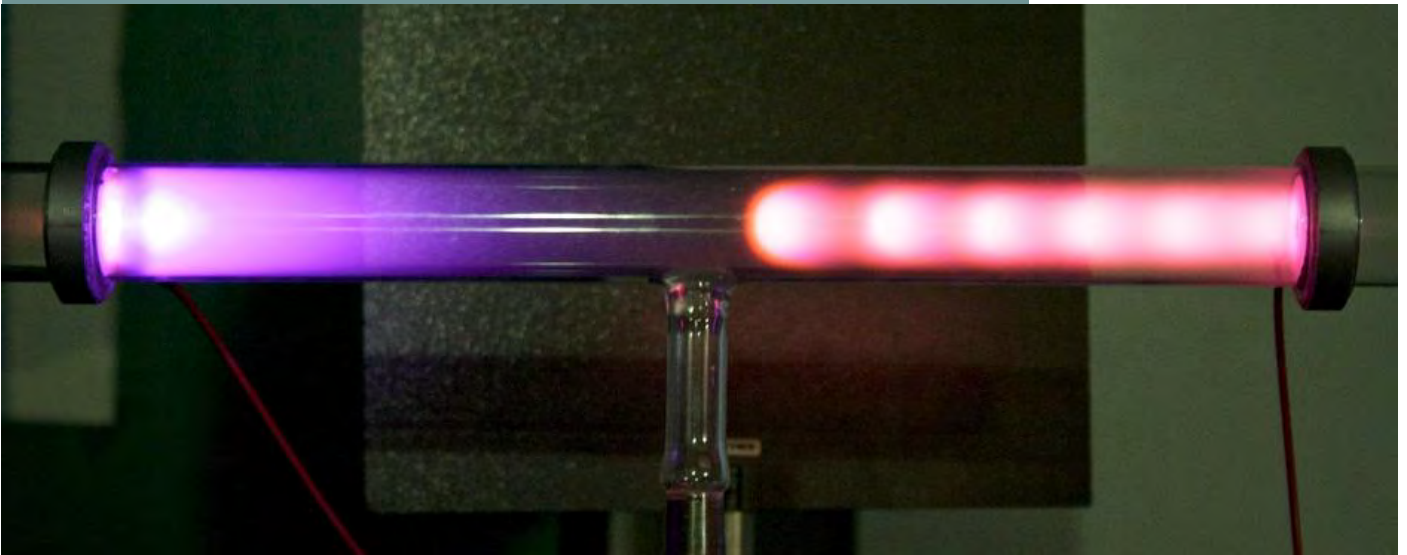

Glowing gasses in a gas discharge tube. A dark space can be seen between the glow near the cathode and near the anode. Via [Wikipedia](#).

(The Vacuum Tube from page 85)

an electric current through rarefied gasses could make them glow colourfully, but for many years this was mostly regarded as an interesting curiosity.

It was not until the 1830s, with the experiments of the English chemist and physicist Michael Faraday, that the effects of electricity on rarefied gasses began to be studied more seriously. Faraday subjected a variety of rarefied gasses to electric current, observing their colourful glow, along with a curious “dark space” between the two electrodes. Faraday was a well-regarded scientist and others took notice of his work: in 1855, Julius Plücker, a German scientist who “idolized Faraday”, endeavoured to replicate Faraday’s experiments. To perform the experiments, Plücker obtained some highly evacuated glass tubes from the well-known instrument maker Heinrich Geissler. Geissler had built a vacuum pump capable of achieving a far lower vacuum than any pump previously and Geissler’s tubes could function over a range of temperatures thanks to their platinum lead-in wires. (Platinum has nearly the same coefficient of thermal expansion as glass; several decades later, Edison would use the same strategy of platinum lead-in wires for this first incandescent light bulb.) These would later be known as “Geissler tubes”.

By using a series of well-crafted, highly evacuated glass tubes “of ever-escalating complexity”, Plücker followed Faraday’s footsteps in investigating the behaviour of electrical

discharge through highly rarefied gasses. During his experiments, Plücker observed what appeared to be some sort of emanation from the negative electrode (cathode). These emanations moved in a straight line, could be deflected by a magnetic field and caused the wall of the tube near the positive electrode (anode) to glow green. Other scientists, including William Crookes and Plücker’s collaborator Johann Hittorf, investigated these emanations further and they eventually came to be known as “cathode rays.” The tubes used to study cathode rays began to be referred to as “Hittorf tubes” or “Crookes tubes” and proved to be an important scientific instrument for studying the nature of matter. In 1895, the German physicist Wilhelm Roentgen, using a Crookes tube to study cathode rays, stumbled upon X-rays, for which he would be awarded the first Nobel Prize in physics in 1901. In 1897, the British physicist J.J. Thomson discovered that cathode rays were actually streams of negatively charged particles — which were dubbed ‘electrons’ — for which he was awarded the Nobel Prize in physics in 1906.

The other line of development for vacuum tubes was via incandescent lights. In 1802, the British scientist Humphry Davy created an incandescent light by connecting a thin strip of platinum to a “battery of immense size” and over the next several decades more than a dozen scientists and inventors tried their hand at creating an incandescent light by enclosing a filament in a glass bulb containing a vacuum or inert gas. But it

(Continued on page 87)

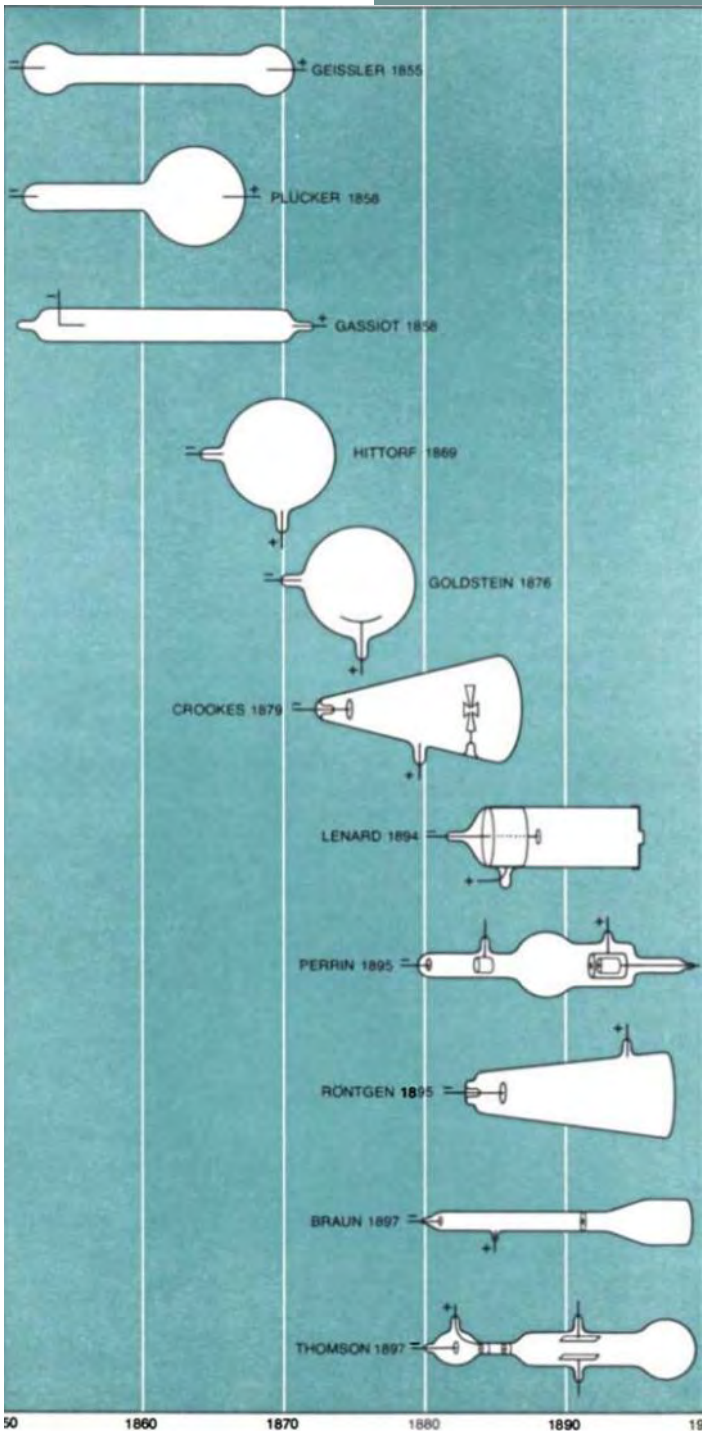

Various 19th century experimental vacuum tubes, via Shiers 1974

was not until 1879 that a practical incandescent bulb was invented, simultaneously by Thomas Edison in the US and Joseph Swan in the UK. Edison's success was in large part due to achieving higher levels of vacuum than had previously been possible, obtained by way of a highly modified Sprengler mercury vacuum pump, first invented in 1865.

Early incandescent bulbs had the tendency to gradually blacken on the interior, reducing the light

emitted and eventually rendering the bulb unusable. While studying this phenomenon in the hopes of eliminating it, Edison placed a small metal plate within the bulb of various lamps. It was eventually discovered that electric current was unexpectedly flowing from these metal plates, a phenomenon that Edison modestly dubbed "the Edison Effect." (Today we know this current is due to thermionic emission, electrons being ejected from the hot light bulb filament.)

The rise of the vacuum tube

By the turn of the 20th century there were two types of devices — Crookes tubes and other similar gas-discharge tubes and experimental Edison Effect lamps — in which electrons flowed between electrodes within a highly evacuated glass tube. Over the next several decades, these two devices would spawn a broad array of vacuum tube technology.

In the 1880s, British scientist and engineer John Fleming began studying the Edison Effect and discovered that electric current could flow from the hot filament to the metal plate but not vice versa. In 1904, Fleming used these phenomena to build the [Fleming Valve](#), a vacuum tube which acted as a rectifier converting alternating current into direct current in early radios. Not long after, American inventor Lee de Forest, in the course of trying to invent an improved radio signal detector, added a third element — a metallic grid — between the cathode and the anode in a Fleming valve.

De Forest eventually discovered that by changing the voltage in the metallic grid, the flow of electricity from the cathode to the anode could be controlled, allowing the device to act as an amplifier. De Forest had little idea how his device



De Forest's Audion, via [Wikipedia](#)

(The Vacuum Tube from page 88)

the waveforms of alternating electrical current — current which changes its direction of flow through a circuit periodically. Some high-frequency alternating currents alternated back and forth thousands of times per second, so fast that any recording device that worked by moving a physical object back and forth couldn't keep up. But Braun suspected that cathode rays could be used to make a measuring device for these high frequency currents. If the rays were made to pass through a narrow opening, the glowing spot on the tube would be reduced to a small point. And by using a magnetic field, the path of the beam could be deflected, moving the point of illumination and drawing the shape of the current's waveform. Because a beam of cathode rays had virtually no inertia, it would be able to respond to changes in an electrical current (which would induce changes in the magnetic field) almost instantly. With the help of Franz Müller (an instrument maker who took over Geissler's firm following Geissler's

Braun's cathode ray indicator tube, via Shiers 1974

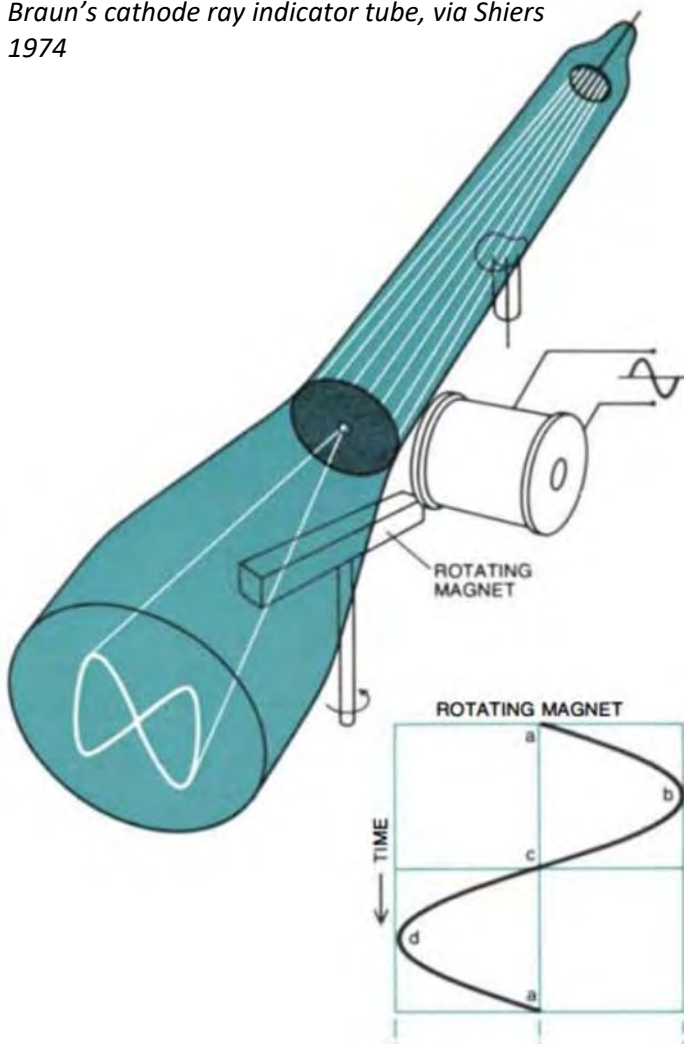

death), Braun had several experimental tubes fabricated and used them to study the behaviour of high-frequency alternating currents, publishing his first paper in 1897. Braun called his device a cathode ray indicator tube.

Braun tubes (more commonly referred to as "cathode ray tubes") became widely used to create electronic displays. Oscilloscopes — devices which show the voltage of a circuit graphically — are directly descended from Braun's cathode ray indicator tubes and in the 1920s cathode ray tubes became the basis for the first television. Inventor Vladimir Zworykin's television system used a specialized cathode ray tube as a video camera to record an image and another cathode ray tube to display it. (A parallel television inventor, Philo Farnsworth, used a cathode ray tube for the TV screen but a slightly different vacuum tube technology for the camera.) Both cathode ray-based video camera tubes and television screens would be the primary television technology for the next several decades, until they were succeeded by flat-panel displays and semiconductor-based cameras.

In the 1920s, cathode rays saw a number of other uses, including building the first electron microscopes. Cathode ray tubes were also used as an early form of computer storage (known as storage tubes or Williams tubes) until they were supplanted by superior memory technology (such as magnetic core memory).

The gas discharge tubes that spawned Braun's cathode ray tube also found numerous other applications. In the 1860s, French engineer Alphonse Dumas and doctor Camille Benoit built the Ruhmkorff lamp, a gas discharge lamp using a Geissler tube connected to a battery-powered induction coil. In the 1890s American inventor Daniel Moore devised his own Geissler tube-based lighting system, known as the Moore Lamp. But it was the discovery of the noble gas neon in 1898 which truly made gas discharge lighting popular. Georges Claude, a French engineer and co-founder of the company Air Liquide, was producing large amounts of neon as a byproduct of air liquefaction and in 1910 displayed a neon light based on a gas discharge tube filled with trace amounts of neon. Other popular lighting

(Continued on page 90)

(The Vacuum Tube from page 89)

technologies — mercury vapor lamps, fluorescent lamps, sodium vapor lamps — were also gas discharge tubes containing different types of gas.

And the gas discharge tube had many applications beyond merely providing lighting. Thyratrons, invented in the 1920s, are gas-discharge tubes that work similarly to vacuum tubes but can handle much higher currents. The pixels on a plasma TV are made up of millions of tiny gas discharge tubes. Gas discharge tubes are used to build, among other things, carbon dioxide lasers, Geiger counters and surge protectors.

Gas discharge lamps generate light (a type of electromagnetic radiation) by using electric current to excite gas molecules within the tube. But vacuum tubes could also be used to generate other sorts of electromagnetic radiation. As we have noted, Wilhelm Roentgen accidentally discovered that a Crookes tube generated X-rays in the 1890s and today, modern X-ray machines still use vacuum tubes to generate X-rays. In the 1920s, researchers at General Electric invented the magnetron, a vacuum tube originally conceived as an electronic switch, but which was later discovered could generate microwaves. An improved version of the magnetron developed by the British during WWII, the cavity magnetron, made aircraft-mounted microwave radar possible, becoming one of the most important inventions of the war. Following the war, it was discovered that magnetron-emitted microwave radiation could be



Ruhmkorff lamp, via [Wikipedia](#)

used to heat food and magnetrons are still found in microwaves today. The Klystron, another powerful tube-based microwave emitter, was invented by the American engineers Russell and Sigurd Varian in the 1930s and found a wide range of uses: Klystrons provide power for particle accelerators like Stanford's SLAC, are the heart of radiation therapy machines for cancer treatment and are used for things like food scanning and medical sterilization. Gyrotrons, vacuum tubes which can generate even higher-frequency radiation, are used to heat the plasma in fusion energy experiments.

Beyond their use in particle accelerators and fusion energy experiments, vacuum tube-based devices were powerful instruments for enabling scientific research. Four Nobel Prizes were the product of vacuum tube devices (five if you include Irving Langmuir's research on incandescent light filaments, which netted him the Nobel Prize in Chemistry in 1932.) In addition to the ones, we have already mentioned — Roentgen's discovery of X-rays, J.J. Thompson's discovery of the electron — Ernst Ruska won the 1986 prize for his work on the electron microscope and Owen Richardson won the 1928 prize for his studies of thermionic emission. And the indirect impact of vacuum tubes on science was likely larger still. Vacuum tube devices powered numerous scientific instruments and investigation into the behaviour of vacuum tubes

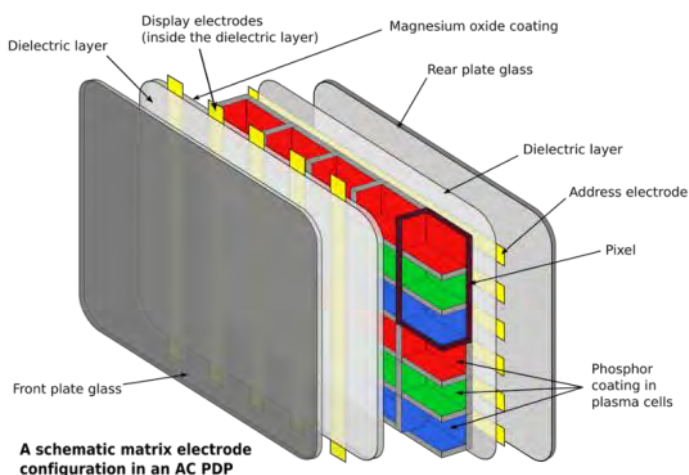

Structure of a plasma display, via [Wikipedia](#)

(Continued on page 91)

(The Vacuum Tube from page 90)

spawned a line of research that resulted in the discovery of electron diffraction and Bell Labs' first Nobel Prize.

Conclusion

In [my book](#) I describe technological progress as a series of overlapping S-curves. A technology comes along, improving slowly at first and then more rapidly, eventually reaching some performance ceiling after which it gets replaced by some successor technology which is on its own, higher-baseline S-curve. And while I think at a high level this is correct, it fails to capture the Cambrian explosion that can follow some new technology coming into the world. The vacuum tube was not a single device, but an entire panoply of devices that used the same basic principle — electrons being emitted off a cathode — in a variety of different ways. These devices all advanced along their own S-curves, improving at different rates and plateauing



X-ray tube, via [Wikipedia](#)

at different times. Many of them have since been supplanted by successor technologies (often based on semiconductors, another broad category of device with many specific implementations), but many of them — magnetrons in microwaves, gas discharge tubes in gas lasers, gyrotrons in fusion energy experiments — remain in use today.

FCC Approves Limited Emergency Use of 70 cm Band by AST Space-Mobile Satellites Outside the US

The ARRL Letter for 1 May 2026

On 21 April 2026, the Federal Communications Commission (FCC) granted AST SpaceMobile limited authorization when not over the United States to use five 50-kHz channels in the 430 – 440 MHz secondary amateur band for emergency Telemetry, Tracking and Control (TT&C) operations for its planned satellite constellation ([DA-26-391 Docket No. 25-201](#)). The authorization applies only for communication with five specified earth stations, each located well outside of the United States and for which the foreign administration with jurisdiction also must separately authorize the communications.

More than 2 500 comments were filed during the proceeding including filings from ARRL and other member societies of the International Amateur Radio Union (IARU), AMSAT and individual radio amateurs worldwide.

After considering the filed comments, the FCC narrowed the requested authorization to emergency TT&C only and further provided that:

- ◆ Use of these frequencies is permitted only in emergencies when no other spectrum is

available

- ◆ Each emergency event is limited to no more than 24 hours
- ◆ Transmissions are restricted to five specific centre frequencies (430,5; 432,3; 434,1; 435,9 and 439,5 MHz), each with no more than 50 kHz bandwidth

In a 29 April 2026 [statement](#), the IARU expressed concern with the FCC's use of Article 4.4 of the ITU Radio Regulations, which allows administrations to authorize non-standard frequency use under certain conditions. The IARU stated that other frequency bands allocated for satellite TT&C should have been used instead of amateur spectrum and encouraged amateurs to report any interference to their national regulators.

The ARRL filed comments (see ARRL News) in July ([PDF](#)) and August 2025 ([PDF](#)) opposing the application, arguing that:

- ◆ The request represented an unprecedented use of secondary amateur spectrum for an unallocated use by a large commercial



(Continued on page 92)

(Off-Centre-Fed Dipoles from page 91)

satellite constellation

- ◆ Such operations could cause harmful interference, particularly to amateur satellites in the 435 – 438 MHz sub-band
- ◆ The FCC should avoid authorizing non-allocated uses that could impact primary allocations for amateur services in other countries

While the FCC ultimately granted the authorization, it imposed the above significant

limitations in response to these concerns that reduce the likelihood of interference.

In the US, reports of suspected interference to amateur spectrum can be shared with the ARRL Regulatory Information Manager, e-mail reginfo@arrl.org.

The ARRL will oppose any similar unallocated uses of spectrum used by amateurs that might cause harmful interference to amateur services and will monitor this situation.

The SARL Awards Dinner on 2 May 2026

Thanks to Kevern, ZR2BK and Eugenie Burger for the photos





The Master of Ceremonies and Kevern, ZR2BK welcoming everybody on behalf of PEARS



Nico, ZS6QL addressing the dinner guests as outgoing President.

Nico, ZS6QL fastening the Chain of Office around the neck of the new President, Guy, ZS6GUY



And there was more delicious food!



Guy, ZS6GUY and Nico, ZS6QL
 Rassie, ZS1YT and Dennis, ZS4BS received Long Service Awards for serving on Council for more than 25 years
 Sid, ZS5AYC receiving his Honorary Life Membership badge from Nico, ZS6QL



Adele, ZS5APT receiving the Willie Wilson Gold Badge from Nico, ZS6QL

Michael, ZS1MJT receiving the Willie Wilson Gold Badge from Nico, ZS6QL. Michael asked his Mom to join him to say thank you for her support of his activities



Gert, ZS6GC receiving his Willie Wilson Gold Badge from Nico, ZS6QL. Gert also received the SAATI Technology Award



Theunis, ZS2EC and Dave, ZS2DH received the Koos & Annie vd Merwe Platinum Award.



Chris, ZS2AAW; Andrew, ZS2G and Glen, ZS2GV received the Koos & Annie vd Merwe Gold Award.



David, ZS1GA and Christo, ZS1CBY received the Jack Twine Merit Award





Odette, ZS2OD; Andrew, ZS2AFB; Eric, ZS2ECH; Pauls, ZS2PS and Vaughan, ZS2VR received the Jack Twine Merit Award. Jan, ZS4JAN joined the ranks of the SARL Hall of Fame Adele, ZS5APT and Sid, ZS5AYC were the HOTA activators for 2025, while Petrus, ZU3PL received the Brian Jones, ZS6BV SOTA Award for 2025





ZS-SOTA Awards
*The Tyler SOTA Excellence Award went to Brandon, ZS6LZ.
The Queens of the Mountain Awards went to Esmarie, ZS3EL and Magda, ZS6MMS.
The ZS-SOTA Ten Regions Challenge went to Esmarie, ZS3EL and Peet, ZS3PL
ZS-SOTA DX Challenge went to Adele, ZS5APT, Sid, ZS5AYC and Brandon, ZS6LZ*



*The JJ Pienaar Trophy for the best article in 2025 is shared by Alan, ZR6AQV and Brandon, ZS6LZ.
Brandon also received the Radio ZS Shield for 2025*





*Ian, ZS6IAI received the Arlund Usher Gold Pen for achieving the highest marks in the 2025 RAE
 Micheal, ZS1MJT received the Hamnet Shield with three other amateurs
 The SARL Young Amateur Excellence Award is shared by Petrus, ZU3PL ad Rulhof, ZS4RM
 The SARL Club Excellence Award went to the Secunda ARC and Gert, ZS6GC accepted the award*



The SARL Certificate of Recognition was presented to Beverly Higgs and Eugenie Burger



Phillip, ZS6PVT received the following awards on behalf of the West Rand ARC - the Silent Keys Memorial Trophy SSB; the SARL Digital Trophy; the Silent Keys Memorial Trophy CW; the HOS Trough; the Club Participation Award (Branch Participant Trophy); the SARL 80 m Championship Trophy (SARL Wednesday 80 m Club Sprint) and the SARL 40 m Club Championship (SARL Saturday 40 m Club Sprint)

Veronica, ZR6TVK receives the SAWRC Trophy for achieving the highest score during the three HF contests in August 2025



The SARL Certificate of Recognition was presented to Odette, ZS2OD; Patsy, ZS2PTY and Gert, ZS2GS



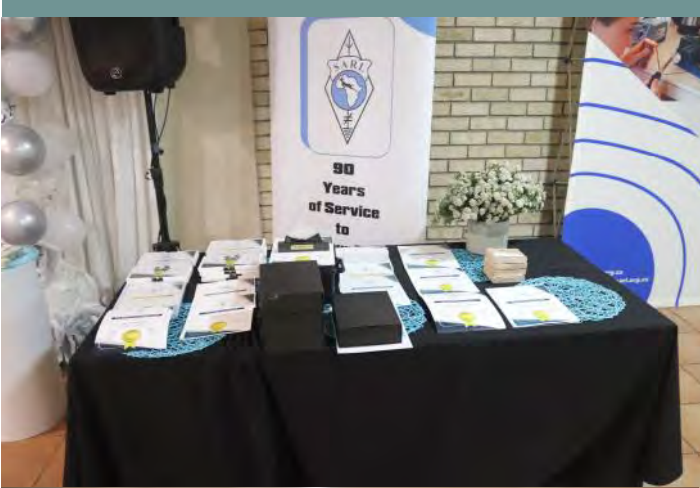

Multiband HF Centre-Loaded Off-Centre-Fed Dipoles

Serge Stroobandt, ON4AA

Copyright 2007–2021, licensed under Creative Commons BY-NC-SA

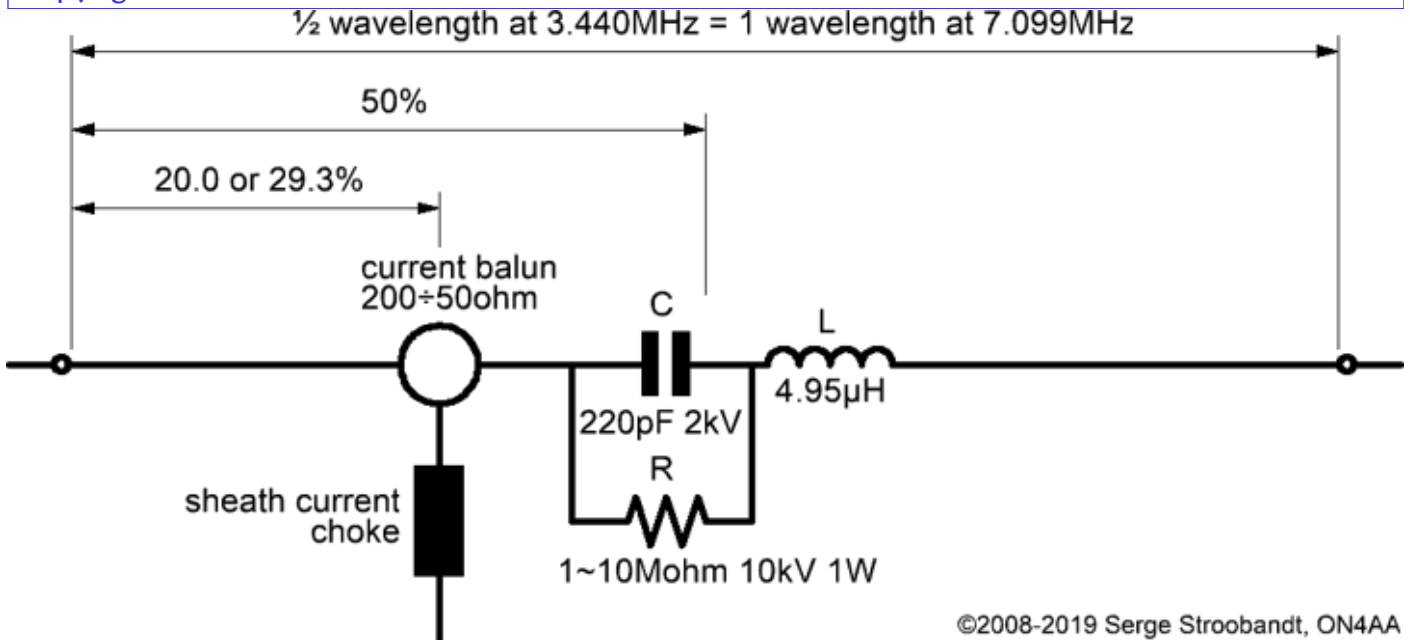

©2008-2019 Serge Stroobandt, ON4AA

Figure 1. ON4AA's CL-OCFD with 80, 40, 30, 20, 15 and 10 m coverage. The capacitor C shortens the dipole for 80 m (actually 75 m) band resonance, whereas the coil lengthens the dipole for 30 m third harmonic resonance. Resistor R has as sole function bleeding off static charges, protecting capacitor C.

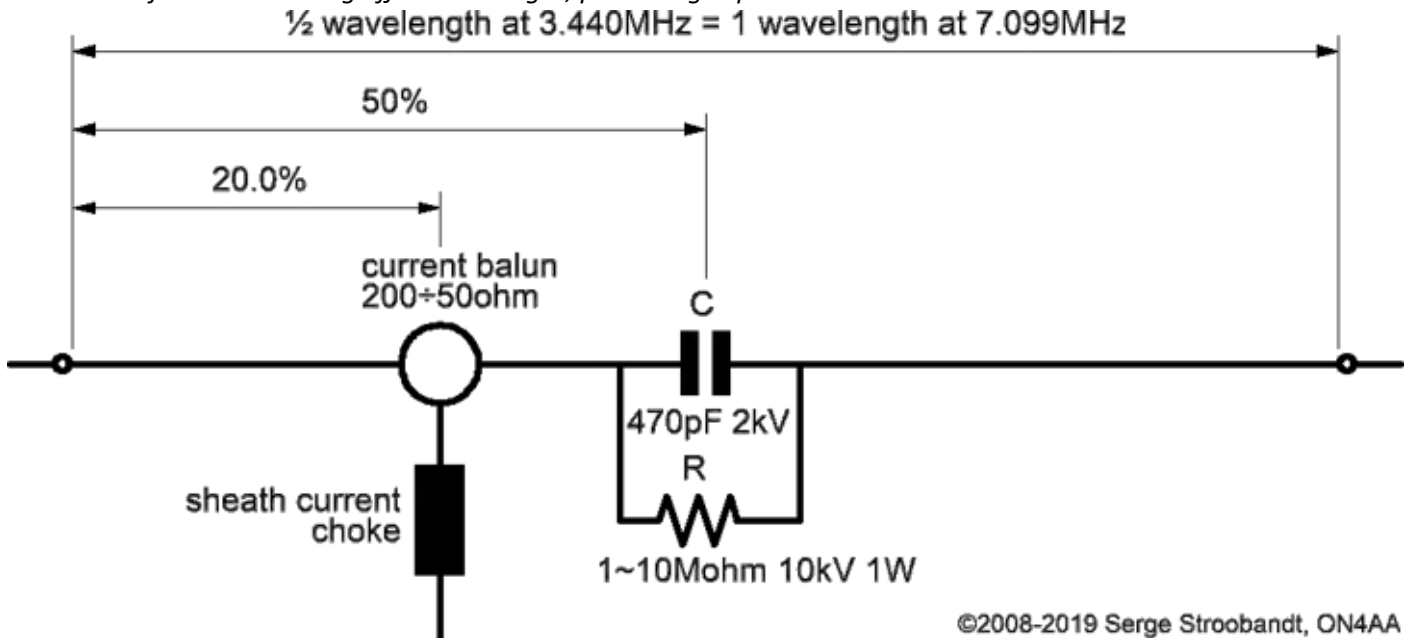

©2008-2019 Serge Stroobandt, ON4AA

Figure 2. ON4AA's 80, 40, 20, 15, 12 and 10m CL-OCFD. The capacitor C renders the dipole resonant on the 80 (actually 75 m), while resistor R has as sole function bleeding off static charges, hence protecting capacitor C. There is no third harmonic resonance on 30 m. However, in return, seventh harmonic resonance is present on 12 m.

Design goals

Like many fellow radio amateurs, I own a fairly standard shortwave radio station consisting of a 100 W HF transceiver driving a 1 kW tube power amplifier. I never chose to spend any money on a kW-rated antenna-tuner. Anyhow, I can tune out VSWRs as high as 3÷1 with the adjustable pi-

network of the output filter tank inside my power amplifier.

Thus, I set out to design an HF antenna with a VSWR of 3÷1, or less, over the full bandwidth of as many



output tank of a PA

(Off-Centre-Fed Dipoles from page 102)

amateur radio HF bands as possible. At the same time, my preference went out to the low- and the non-[WARC bands](#). This design exercise resulted in a new kind of antenna which I dubbed Centre-Loaded Off-Centre-Fed Dipole Antenna, or CL-OCFD for short.

The Centre-Loaded Off-Centre-Fed Dipole (CL-OCFD) was **invented and first described by yours truly, Serge Y. Stroobandt, ON4AA, in the year 2006**. I briefly considered patenting my design. However, I chose not to do so as a way to give back to this wonderful hobby community, which indirectly has given me a lot. If you like or use the CL-OCFD, please, consider [making a donation](#) towards keeping this site on-line.

Companies or individuals selling any CL-OCFD antenna variant are granted the explicit permission to do so, but are kindly solicited to **refer the inventor by name and call sign** in any manual and marketing material.

Performance

In proof of its performance, an EZNEC-calculated VSWR-graph of the CL-OCFD antenna is presented in Figure 2. This antenna works without a tuner over the entire



Having any questions about the CL-OCFD antenna?
Wanting to discuss OCFDs and single-wire-fed Windom antennas?

Post your questions, results and pictures to:

the **OCFD**  **Groups.io**

bandwidth of the 80, 40, 30, 20, 15 and 10 m-band, simply by adjusting the output-tank of your tube power amplifier. - If your final output stage is a transistor amplifier, you definitely will need an antenna-tuner though. - In such, this antenna is the first described single-wire antenna to be offering these capabilities.

Why off-centre-fed?

When offsetting the feed position of a dipole antenna away from its centre, at some point, similar feed impedances can be obtained for a number of frequency bands. This occurs at the fundamental ($\lambda/2$ dipole) resonant frequency as well as several harmonic resonant frequencies.

This is possible because a standing wave is present along the dipole which causes the feed impedance to change. In the span of a quarter wavelength, it varies from a very high value at the antenna ends (several k Ω) to the value of the radiation resistance at the corresponding frequency.

At its fundamental resonant frequency, in free

(Continued on page 104)

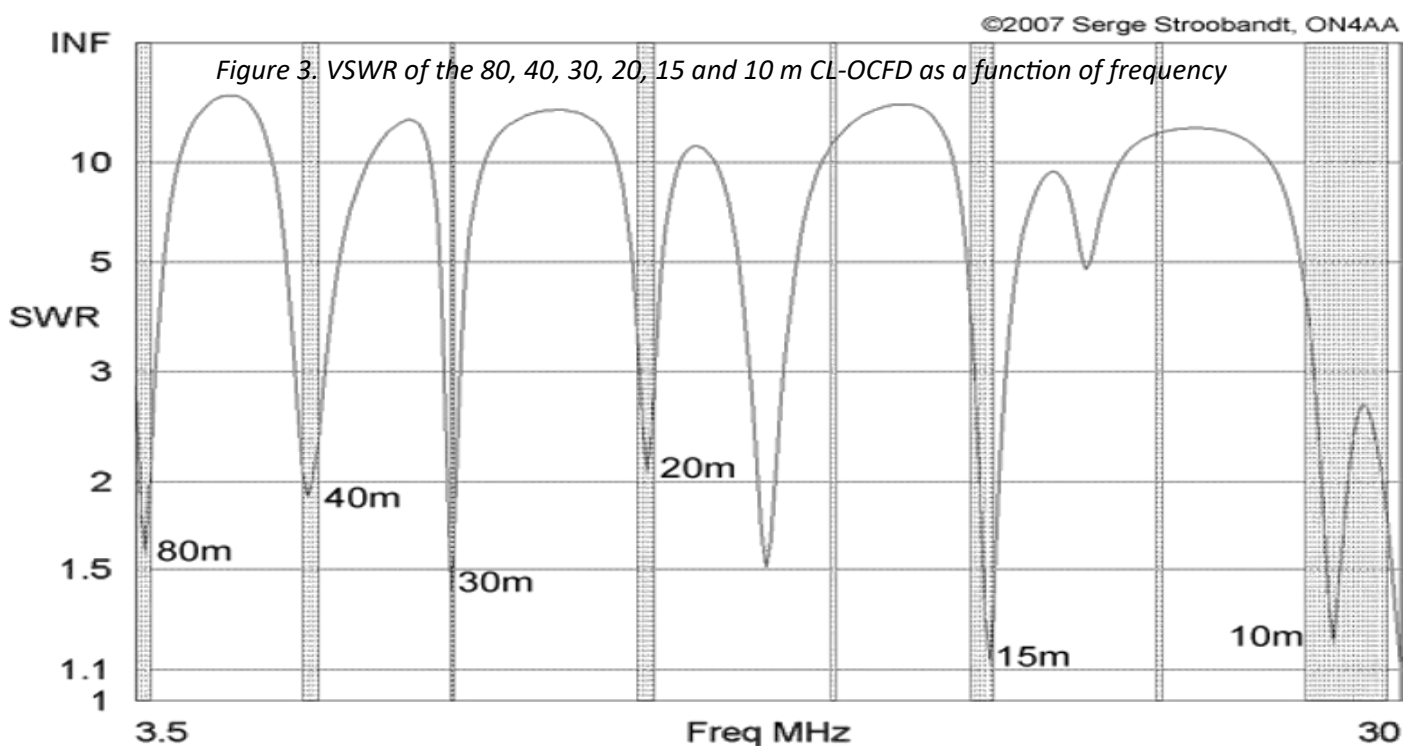

(Off-Centre-Fed Dipoles from page 103)

space and for an infinitesimal thin wire, the dipole's theoretical centre feed impedance would be 73 Ω. However, the optimal multiband feed point will have a higher impedance than this theoretical centre feed impedance. Hence, a good quality impedance-transforming balun will be necessary to match the optimal balanced feed impedance to that of the unbalanced coaxial feed cable.

Full 80 m-band coverage

Operating a centre-fed dipole over the entire 80 m-band turns out to be particularly challenging. With 8.2% relative bandwidth the 80 m-band (3,5 – 3,8 MHz) is exceptionally broad. *full 80 m-band coverage* some cage dipoles or load switching arrangements deliver only partially satisfactory results.



However, any OCF dipole easily outperforms aforementioned obtrusive antenna arrangements.^{1,2} Here is why:

Placing the feed point away from the centre, increases the resistive part of the feed impedance and source load more than the reactive (imaginary) part of the resonant antenna, which is nearly resonant. This effectively lowers the loaded Q-factor of the antenna at the feed point. Offsetting the feed position of a dipole antenna, will result in a lower loaded Q-factor and hence a broader working bandwidth at the fundamental frequency.

$$Q_{\text{loaded}} \downarrow \equiv \frac{X_{\text{in}}}{R_{\text{in}} \uparrow + R_{\text{source}} \uparrow} \text{ and } Q_{\text{loaded}} = \frac{f_{\text{res}}}{\text{BW}} \Rightarrow \text{BW} \uparrow = \frac{f_{\text{res}}}{Q_{\text{loaded}} \downarrow} \quad (1)$$

In summary, offset feeding causes the antenna to be loaded differently. The effect is most pronounced at the fundamental frequency. This is a first reason why it pays off to build your OCF dipole with 80 m as the fundamental wavelength and not, for example, 160 m. An additional reason will be given in the section about centre-loading.

Literature

Rather than reinventing the wheel, every antenna project should start with a quick literature study of similar published antenna designs. Doing so for the



continuous renewal

Please note that a year after the publication of this article, Eugene G. Preston, K5GP, described a **dual band 160 and 80 m CL-OCFD** exhibiting comparable broadband behaviour on 80 metres.³ However, this 80 m broadband performance is achieved in a slightly different manner. The antenna is actually a 3-band CL-OCFD antenna (160, 80 and 75 m) where the centre loading moves the natural third harmonic to the lower end of the 80 m band, below the 75 m second harmonic.

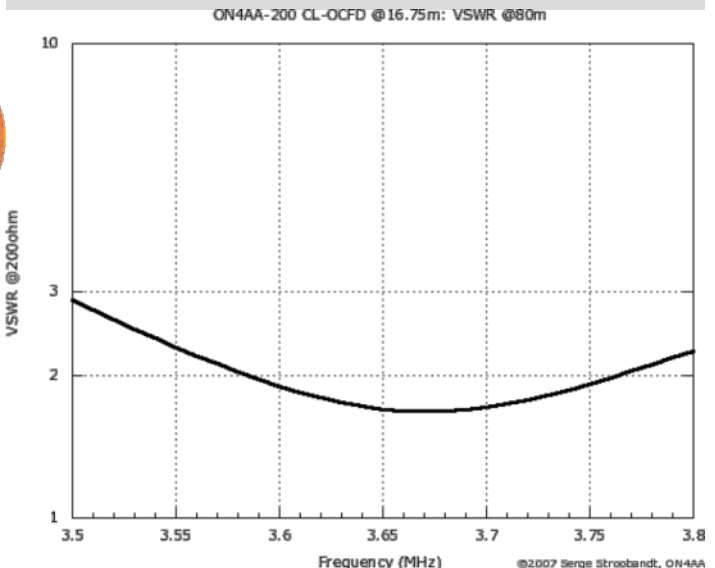

Figure 4. VSWR of the six-band CL-OCFD on 80 m and at a height of 16,75 m (55 ft)

multiband Windom or off-centre-fed dipole antenna (see table below), leads to a stunning revelation. Over many years, antenna dimensions and feed locations have not changed much from the original single-wire design, whereas balun feed impedances have de-creased from 500 Ω to 300 Ω or even 200 Ω! This, of course, is reason enough to become very suspicious about published multiband Windom designs.

As a matter of fact, I first made this table in 2002, when I held the call ON4BAA. It promptly triggered me to start using the power of computer modelling to study this poorly understood antenna. This resulted in two designs; a 300 Ω and a 200 Ω design. Both had feeding locations much closer to the antenna end than usual. This improved the VWSR-performance quite a bit. In 2006, **Tom Rauch, W8JI, reproduced these findings** with a slightly longer bare copper wire antenna.

However, two problems remained:

1. Although the traditional OCF dipole had very

(Continued on page 105)

Table 1: Literature and web survey of multiband OCFDs

| Design | Year | Zin | ℓ_{tot} | ℓ_{short} | Offset* | h_{agl} | config | bands |
|----------------------|------|--------------|----------------------|--------------------|-------------------|---------------------------------|-----------------------------------|--|
| W8GZ | 1929 | 500 Ω | 0,483 λ | 0,18 λ | 37,3% | | Single wire fed | single |
| VS1AA ⁴ | 1937 | 500 Ω | 41,00 m | 13,60 m | 33,2% | | Single wire fed | 80 [†] 40 20 17 12 10 m |
| K4ABT | 1949 | 200 Ω | 40,5 m | 13,4 m | 33,1% | 6 – 12 m | horizontal | 80 40 20 17 12 10 m |
| DJ2KY ⁵ | 1971 | 300 Ω | 42 m | 14 m | 33,3% | | horizontal | |
| “FD4” ⁴ | 1971 | 300 Ω | 41,45 m | 13,50 m | 32,6% | 8 m | Inverted V | 80 [†] 40 20 17 12 10 m |
| “FD4” ⁶ | 1971 | 300 Ω | NA [‡] | NA [‡] | NA [‡] | top: 12 m ends: 8 and 3 m | Asymmet- rical invert- ed V | 80 [†] 40 20 17 12 10 m |
| K8SYH | 70’s | 300 Ω | 39,08 m | 12,74 m | 32,6% | | horizontal | |
| I7SWX ^{7,8} | 1988 | 300 Ω | 41,0 m | 13,5 m | 32,9% | | horizontal | |
| JA7KPI | 1994 | 200 Ω | 41,0 m | 13,6 m | 33,2% | 11m | Inverted V | 80 40 20 17 10 m |
| K3MT | 1997 | 450 Ω | 42,06 m | 12,65 m | 30,1% | top: 14 m ends: 5 m | Asymmet- rical invert- ed V | 80 [†] 40 20 17 15 12 10 m |
| ON4BAA | 2002 | 300 Ω | 41,00 m [§] | 8,10 m | 19,8% | 14 m | horizontal | 80 [†] 40 20 15 12 10 m |
| ON4BAA | 2003 | 200 Ω | 41,00 m [§] | 6,25 m | 15,2% | 14 m | horizontal | 80 40 20 17 10 m |
| W8JI | 2006 | 300 Ω | 41,8 m | 8,35 m | 20,0% | | horizontal | 80 [†] 40 20 15 10 m |
| ON4AA | 2007 | 200 Ω | 40,66 m [§] | 11,76 m | 28,9% | 17 m | centre- load | 80 40 30 20 15 10 m |
| K5GP | 2008 | 200 Ω | 74,67 m | 14 m | 18,75% | 5,5 m | horizontal | 160 80 75 m |
| ON4AA | 2018 | 200 Ω | 40,66 m [§] | 8,13 m | 20,0% | 15 m | horizontal centre-load | 80 40 30 20 15 10 m |
| ON4AA | 2018 | 200 Ω | 40,66 m [§] | 8,13 or 11,76 m | 20,0% or 29,3% | 15 m | horizontal centre-load | 80 40 30 20 15 10 m |

Table notes:

* The open end of the antenna corresponds to 0% offset, the middle of the dipole to 50%.

[†] VSWR $\leq 3\div 1$ only within a narrow portion of the 80 m-band.

[‡] Inconsistent data in brochure; end-insulator separation and heights do not correspond to angle between dipole legs at specified height.

[§] Antenna made of soft PVC insulated **HO7 V-K 4 wire**.

(Off-Centre-Fed Dipoles from page 104)

broad band-segments, the VSWR-minima of either the 80 m or the 40 m-band could not be perfectly aligned to the respective band-centres. Also, designs that did better on 80 m, lack 15 m. Apparently, OCF dipole designs had so far been a compromise between these three bands. The

renowned “FD4” antenna was not an exception; Have a look at its VSWR specification on pages 13 and 14 of this **brochure**.

2. Furthermore, none of these designs offered 30 m. This is a pity, because most amateurs would put up a wire antenna especially for the lower bands

(Continued on page 106)

(Off-Centre-Fed Dipoles from page 105)

where beam antennas are more difficult to erect. The next section explains why traditional OCF dipoles have these inherent limitations. Rest assured, both problems are dealt with by the CL-OCFD, also listed at the bottom of Table 1.

Resonant lengths

It is often said that the HF amateur radio bands are **harmonics** of the 80 m-band. But is this really the case? The statement can easily be tested by considering a horizontal wire at a practical height (16.75 m or 55 ft) above a typical city lot ($\sigma = 1 \text{ mS/m}$; $\epsilon_r = 5$). I use **gauge 4 mm² copper wire insulated by a 0.8 mm-thick layer of soft PVC**. For the remainder of only *this* section, the length of the wire is such that it achieves $\lambda/2$ dipole resonance at the **geometric** centre frequency f_c of the Region 1 80 m-band (3,647 MHz). At the geometric centre frequency of every other band, we will now determine how much wire needs to be added or subtracted to achieve **harmonic** resonance. It should be very little if the bands were truly harmonic.

Note that bare copper wire at higher heights and above better ground would yield longer resonant lengths, due to less capacitive coupling to the ground. Either way, this does not affect the validity of what follows. Let us now look at the even and odd harmonics in separate groups, starting with the even harmonics.

Even harmonics

Table 2 clearly shows that the lower band-edges are exactly harmonic; all frequencies are integer multiples of 7.000 MHz. All even harmonic bands also have similar relative bandwidths; i.e. higher harmonic bands become proportionally wider. (The FM-portion of the 10 m-band is temporarily left out of consideration.) Consequently, the **geometric** centre frequencies of the even harmonic bands are also more or less harmonic and their harmonic resonant lengths almost equal. This is reflected in a low value for the **standard deviation** of the harmonic resonant lengths. In conclusion, it must be relatively easy to design an off-centre-fed dipole for this set of even harmonics, provided we find a feed position with comparable feed impedances for all these frequencies.

In this example, the **arithmetic mean** of the even harmonic resonant lengths is 40,66 m (133,4 ft). The mean resonant length corresponds to a fundamental resonant frequency of 3,440 MHz. We will keep this in mind for trimming our antenna once it is hung.

Odd harmonics

Let us continue and have a look now at the odd harmonics. The situation turns out completely different. Even though 3,500 MHz is exactly one

(Continued on page 107)

Table 2. Resonant length of even harmonics

| band | f_l (MHz) | f_u (MHz) | f_c (MHz) | harmonic | length | Δ |
|------|-------------|-------------|-------------|---------------------------|---------|----------|
| 40 m | 7,000 | 7,200 | 7,099 | 2 | 40,52 m | -0,14 m |
| 20 m | 14,000 | 14,350 | 14,174 | 4 | 40,75 m | 0,09 m |
| 15 m | 21,000 | 21,450 | 21,224 | 6 | 40,87 m | 0,22 m |
| 10 m | 28,000 | 29,200 | 28,594 | 8 | 40,49 m | -0,17 m |
| | | | | arithmetic mean | 40,66 m | |
| | | | | standard deviation | 0,16 m | |

Table 3. Resonant length of odd harmonics and required centre-load for resonance with 40,66 m (133,4 ft) wire length

| band | f_l (MHz) | f_u (MHz) | f_c (MHz) | harmonic | length | XCL |
|------|-------------|-------------|-------------|---------------------------|---------|----------------|
| 80 m | 3,500 | 3,800 | 3,647 | 1 | 38,68 m | -j91 Ω |
| 30 m | 10,100 | 10,150 | 10,125 | 3 | 42,76 m | +j241 Ω |
| 17 m | 18,068 | 18,168 | 18,118 | 5 | 39,89 m | -j153 Ω |
| 12 m | 24,890 | 24,990 | 24,940 | 7 | 40,61 m | -j12 Ω |
| | | | | standard deviation | 1,48 m | |

(Off-Centre-Fed Dipoles from page 106)

half of 7,000 MHz, the resonant length of the 80 m-band is, at its geometric frequency, much shorter than the mean resonant length of the even harmonic centre bands. This is because, with 8,2%, the 80 m band has the broadest relative bandwidth of all amateur HF bands. It easily surpasses the 5,9% of the entire 10 m-band (28,000 – 29,700 MHz).

The 30 m band is equally problematic, being not even a real harmonic. Its resonant length is much longer than the mean of 40.66 m for the even harmonics.

Finally, we see that 17 and 12 m behave very well. The resonant length of the 12 m-band nearly coincides with the mean resonant length of the even harmonic bands.

Remember the problems with the OCF antennas discussed in the previous literature survey? This should no longer astonish us. Above tables revealed that the resonant lengths of the 80 and 30 m bands are true outliers compared to the harmonic resonant lengths of the other HF bands. It is the underlying cause for the partial 80 m coverage and the complete absence of 30 m-band coverage in prevalent OCF antenna designs.

Read on to see how both problems can be solved.

Centre-loading

Below diagram shows the current distribution along an antenna wire for its first eight harmonic resonances. The current distributions of the even harmonics are plotted above the wire, those of the

Figure 5. Current distribution of the first eight harmonic resonances along an antenna wire

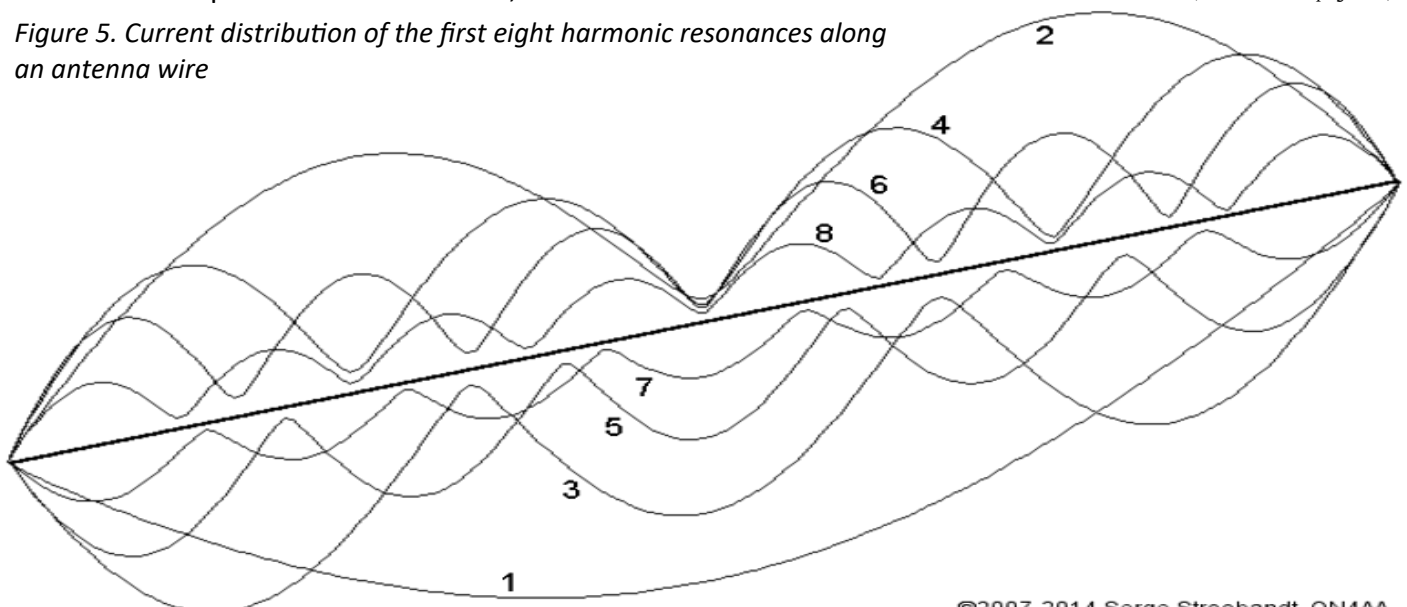

odd harmonics below. Do you notice anything special?

At least, I do. It may seem trivial, but all even harmonics have (almost) zero current at the centre of the antenna, whereas all odd harmonics experience a current maximum at this location.

Zero current for the even harmonics at the centre, implies that I can literally do what I want at the centre of the antenna without upsetting the even harmonics. I can even cut the antenna in two! As a matter of fact, this is precisely what we are going to do!

It might seem unfortunate that the wavelengths of the 80 m and 30 m-bands are too short, respectively, too long to be true harmonics of the other bands. However, luck struck upon seeing that both problematic bands happen to be odd harmonics. Please, note that this statement does not hold when considering a double-sized OCFD with 160 m as the fundamental frequency. This antenna design is therefore not scalable!

What remains to be done now, is to cut the antenna in half and insert a centre-loading network in series. This network will need to add the necessary centre loading reactances X_{CL} (see Table 3 above) in order to render the antenna resonant at the odd harmonics. As mentioned before,

(Continued on page 108)

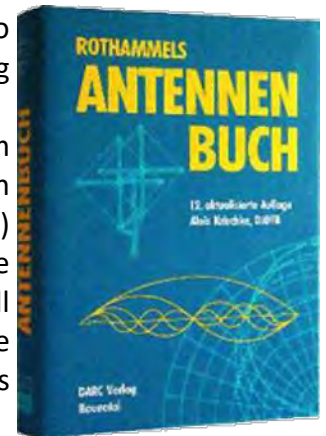

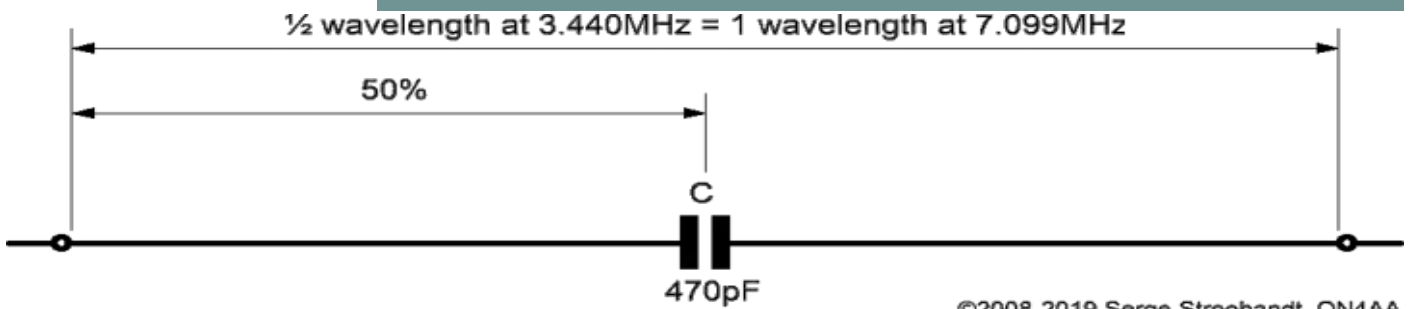

Figure 6. A centre-loaded wire, resonant on six bands; four even harmonics (40, 20, 15 and 10 m) and one odd harmonic (80 m). The capacitor has a nominal value of 470 pF. Its effective capacitance should be about 478 pF at 3,647 MHz.

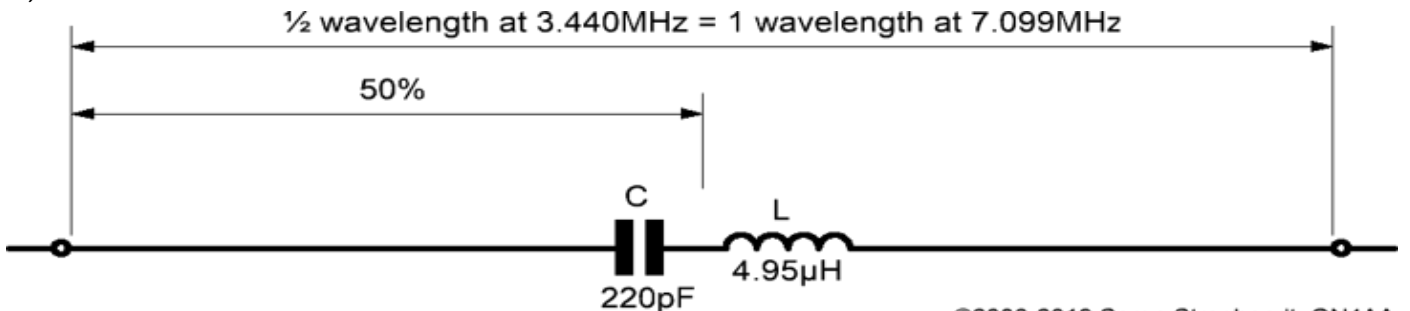

Figure 7. A centre-loaded wire, resonant on six bands; four even harmonics (40, 20, 15 and 10 m) and two odd harmonics (80 and 30 m)

(Off-Centre-Fed Dipoles from page 107)

resonance makes matching at multiple frequencies a lot easier.

harmonic of 12 m because the capacitor of 470 pF corresponds to a reactance of $-j13,5$ at 24,990 MHz.

Capacitive centre load

Let us start easy. When we have a 40,66 m (133,4 ft) long wire hanging in our garden, at least we would like it to be also perfectly resonant on the popular 80 m-band. Table 3 told us that the wire is too long for resonance at 80 m. A capacitive reactance of $-j91,3 \Omega$ needs to be put in series at the centre of the antenna. At 3,647 MHz this corresponds to ******a centre load capacitor of 478 pF, say 470 pF.

However, by placing this capacitor at the centre, we will upset the other odd harmonic resonances, namely 30 and 17 m. By coincidence, the antenna remains resonant on the odd

Series LC centre load

Now let us try to regain another odd harmonic, in addition to the already re-covered 80 m band. For some, but not all odd harmonics, this can be done by loading the centre of the antenna with a series LC network (see Table 4).

More bands?

Yeah, right. Let me disappoint you by saying that things are not as easy as adding just one additional reactive element in series or parallel to obtain yet another band. After all, the centre load impedance X_{CL} would have to change sign twice. However,

(Continued on page 109)

Table 4. Centre-loading series LC networks for odd harmonic resonance

| f_{odd} (MHz) | X_{CL} @f | odd harmonics | C | L | f_{res} (MHz) | X_L @f |
|------------------------|-----------------|---------------|--------|--------------------|------------------------|------------------|
| 3,647 | $-j91,3 \Omega$ | 80 m | 478 pF | no L | no L | no L |
| 10,125 | $+j241 \Omega$ | 80 and 30 m | 213 pF | 4,95 μH | 4,900 | $+j314,7 \Omega$ |
| 18,118 | $-j153 \Omega$ | 80 and 17 m | 692 pF | no solution! | no solution! | no solution! |
| 24,940 | $-j11,8 \Omega$ | 80 and 12 m | 477 pF | 10,1 nH | 72,486 | $+j1,58 \Omega$ |

Example: second row in above table

Placing a 213 pF, say 220 pF, capacitor in series with a 4,95 μH inductor at the centre of the antenna will make the antenna resonant at 80 and 30 m, as well as all even harmonics. The resonant frequency of the centre load will be 4,900 MHz. At 10,125 MHz, the series inductor L should have a (measured) reactance of $+j314,7 \Omega$. Knowing these values helps with the design and fine-tuning of the series inductor L.

Derivation of series LC centre load component values

The centre load component values C and L in Table 4, as well as their resonant frequency f_{res} are obtained as follows.

$$\begin{cases} \omega_1 L - \frac{1}{\omega_1 C} = X_1 & \text{(I)} \\ \omega_2 L - \frac{1}{\omega_2 C} = X_2 & \text{(II)} \end{cases} \quad (2)$$

ω_1 and ω_2 represent the radial frequencies of the geometric centre of any of two odd harmonic bands in Table 4, whereby $\omega_i = \tau \cdot f_{odd,i} = 2\pi \cdot f_{odd,i}$, whereas X_1 and X_2 are the required reactances.

$$\text{(I)} \Rightarrow L = \frac{1}{\omega_1} \left[X_1 + \frac{1}{\omega_1 C} \right] \quad \text{(III)} \quad (3)$$

$$\text{(III) in (II)}: \frac{\omega_2}{\omega_1} \left[X_1 + \frac{1}{\omega_1 C} \right] - \frac{1}{\omega_2 C} = X_2 \quad (4)$$

$$\Rightarrow \left[\frac{\omega_2}{\omega_1^2} - \frac{1}{\omega_2} \right] \frac{1}{C} = X_2 - \frac{\omega_2}{\omega_1} X_1 \quad (5)$$

$$\Rightarrow C = \left[\frac{\omega_2}{\omega_1^2} - \frac{1}{\omega_2} \right] \left[\frac{\omega_1}{\omega_1} X_2 - \frac{\omega_2}{\omega_1} X_1 \right]^{-1} \quad (6)$$

$$\Rightarrow C = \left[\frac{\omega_2}{\omega_1^2} - \frac{1}{\omega_2} \right] \frac{\omega_1}{\omega_1 X_2 - \omega_2 X_1} = \left[\frac{\omega_2}{\omega_1} - \frac{\omega_1}{\omega_2} \right] \frac{1}{\omega_1 X_2 - \omega_2 X_1} \quad (7)$$

$$\Rightarrow C = \frac{\omega_2^2 - \omega_1^2}{\omega_1 \omega_2 (\omega_1 X_2 - \omega_2 X_1)} \quad \text{(IV)} \quad (8)$$

Both C and L are known at this point, but the expression for L is further developed:

$$\text{(IV) in (III)}: L = \frac{1}{\omega_1} \left[X_1 + \frac{\omega_2 (\omega_1 X_2 - \omega_2 X_1)}{\omega_2^2 - \omega_1^2} \right] \quad (9)$$

$$\Rightarrow L = \frac{1}{\omega_1} \left[\frac{\omega_2^2 X_1 - \omega_1^2 X_1 + \omega_1 \omega_2 X_2 - \omega_2^2 X_1}{\omega_2^2 - \omega_1^2} \right] \quad (10)$$

$$\Rightarrow L = \frac{\omega_2 X_2 - \omega_1 X_1}{\omega_2^2 - \omega_1^2} \quad (11)$$

Hence, the resonant frequency of the center load:

$$\omega_{res} = \frac{1}{\sqrt{LC}} = [LC]^{-\frac{1}{2}} = \left[\frac{\omega_2 X_2 - \omega_1 X_1}{\omega_1 \omega_2 (\omega_1 X_2 - \omega_2 X_1)} \right]^{-\frac{1}{2}} \quad (12)$$

$$\Rightarrow \omega_{res} = \sqrt{\omega_1 \omega_2 \frac{\omega_1 X_2 - \omega_2 X_1}{\omega_2 X_2 - \omega_1 X_1}} \quad \text{and} \quad f_{res} = \frac{\omega_{res}}{2\pi} \quad (13)$$

(Off-Centre-Fed Dipoles from page 108)

theoretically it should be possible to devise a passive net-work that makes the antenna resonant on all odd harmonic bands. Nonetheless, such a network will be far from practical to have it hanging along a wire.

Moreover, it remains to be seen whether a low VSWR feed point can be found that accommodates all these bands (see next section). The challenge is there for the taker!

As mentioned before, it is not possible to scale this antenna to a longer 160 m-version. Would one try to do so, the problematic 80 m-band would become an even harmonic and hence impossible to be influenced by centre-loading the antenna.

The 6 m-band (50 – 52 MHz) is the 14th harmonic of the 80 m-band. Being such a high harmonic, it becomes prohibitively difficult to pinpoint a low VSWR 6 m-band feeding offset.

No resonant traps

Please, do allow me to tackle some anticipated criticism. Uninformed spirits may argue that the two-element network of this antenna is a resonant trap adding significant loss.

This is clearly not the case! The two-element centre-loading network is not resonant at any of the amateur bands and is therefore not acting as a trap. It is strictly a loading network, adding relatively little reactance. As such, it does not contribute more loss than any other loading inductors commonly employed in the very best of commercial and home-made low-band Yagi-Uda de-signs.

Optimal offset and input impedance

Now that the antenna can be made resonant on six bands, a «sweet spot» needs to be found where VSWR at a given feed impedance is low on all six bands.

To determine this ideal feed offset, VSWR graphs at difference feed impedances are plotted for all frequency bands and all possible offset percent-ages. These are then compared. This is done for the 6-band version of the CL-OCFD which includes 30 m resonance. Note that 0% offset corresponds to the open end of the antenna; 50% offset corresponds to the middle of the dipole.

Below graphs were produced with the antenna

(Continued on page 110)

(Off-Centre-Fed Dipoles from page 109)

at 16,75 m (55 ft) over city ground ($\sigma = 1 \text{ mS/m}$; $\epsilon_r = 5$) in the near field. Running the model with different ground characteristics revealed that the VSWR of the antenna is barely influenced by the RF properties of the ground underneath (not considering height above the ground for the moment.)

Avoid low-impedance sources

Modelling with 4nec2

Here is the **4nec2** input file of the ON4AA 200 Ω CL-OCFD antenna over good RF ground ($\sigma = 10 \text{ mS/m}$; $\epsilon_r = 14$).

The model requires **4nec2** version 5.7.0 or higher. An **EZNEC** model is also available.

About rendering VSWR-offset graphs

Here is an interesting fact: every line of every VSWR-offset graph below has been drawn on the basis of 98 data points. Every single of these data point then again resulted from one complete antenna analysis. In other words, six bands times 98 data points, means 588 **NEC2** runs were necessary to draw just one complete six-band VSWR-offset graph.

In 2002, the only way to obtain such a graph was by undertaking the monastic task of running **EZNEC** 98 times and manually copying 1 176 numbers - input impedances are complex numbers - onto a spreadsheet. This was done so for every of the four VSWR-offset graphs below.

A couple of years later, this task could be automated, thanks to **4nec2**. This excellent antenna modelling interface for NEC2 allows one to sweep any arbitrary antenna variable. What is more, 4nec2 is free-ware. Thank you for that, Arie Voors! Nonetheless, as a **FLOSS** advocate, I am still hoping for Arie to publish the source code. This would safeguard future development should the original developer be no longer around. Even though 4nec2 is coded for MicroSoft Windows™, I run 4nec2 flawlessly on **GNU/Linux** using the equally free **Playon Linux** software.

VSWR versus offset plots were rendered for **150 Ω** and **100 Ω** sources. These plots equally showed points where low VSWR coincided for a number of bands. However, there is one caveat. These VSWR

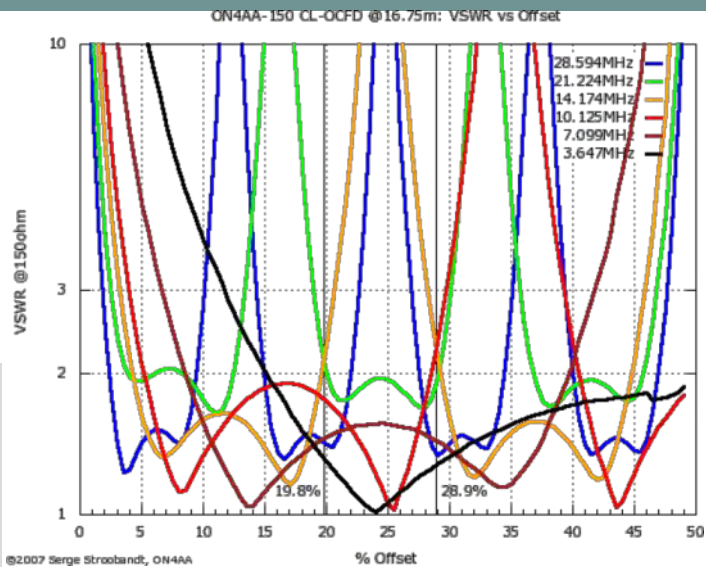

Figure 8. VSWR of the six-band 150 Ω CL-OCFD as a function of feed point offset

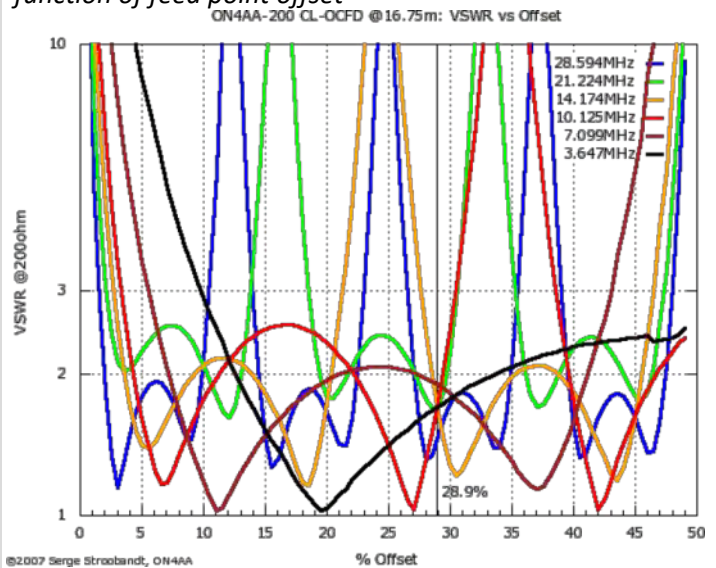

Figure 9. VSWR of the six-band 200 Ω CL-OCFD as a function of feed point offset

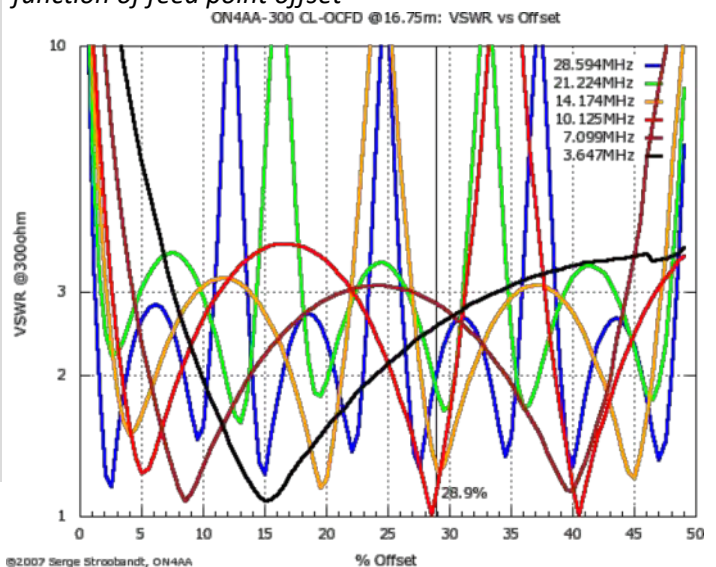

Figure 10. VSWR of the six-band 300 Ω CL-OCFD as a function of feed point offset

(Continued on page 111)

(Off-Centre-Fed Dipoles from page 110)

vs. offset plots are for spot frequencies only. At the band edges, VSWR actually increases a lot with low-impedance sources. (Here are examples for [20 m](#) and [15 m](#) with a 150 Ω source at 19,8% offset.) This happens because using a low-impedance source results in an antenna with a higher loaded Q-factor. Only an antenna with a low loaded Q-factor will provide full 80 m band coverage, as explained before.

Optimal offset with 200 Ω source

For a feed impedance of 200 Ω , all bands yield a VSWR below 2:1 at 29,3% offset.

Avoid a 300 Ω source

Feeding the antenna from a 300 Ω source is not desirable since the VSWR will always be high on at least one of the resonant bands.

Avoid high-impedance sources

With high-impedance sources, VSWR minima increasingly coincide at small offsets, eventually resulting in a high-impedance end-fed antenna. However, high-impedance sources come at the price of increased problems with sheath currents, feed point arcing and wide-band transforming

losses. These designs do exist, but their analysis is beyond the scope of this article.

Designs

Only 200 Ω feeds produce practicable results for a true multi-band design. Therefore, a feed impedance of 200 Ω and a feed offset of 20% or 29.3% are kept as the optimal result of this design exercise. Here is how the 200 Ω six-band CL-OCFD will look like when adding a [10 kV 1 W thick film metal oxide resistor R of about 1 to 10 M \$\Omega\$](#) to bleed off static charges and hence protect the capacitor C from breaking down.

The same optimal offset equally applies to the version of the CL-OCFD with 30 m instead of 12 m-band coverage.

VSWR

Below VSWR curves were rendered with [4nec2](#). The six-band CL-OCFD antenna was modelled hanging at 16,75 m (55 ft) above very poor city ground ($\sigma = 1$ mS/m; $\epsilon_r = 5$). In reality, the VSWR measured in the shack will be lower because of damping by the feed line losses. Here is the [4nec2 input file](#).

(Continued on page 114)

| bands | l_{tot} | Z_{in} | offset* | centre load |
|---------------------|------------------------------------|--------------|---------------|-----------------------|
| 80 40 20 15 12 10 m | $\lambda/2$ at 3,440 MHz | 200 Ω | 20,0% | 470 pF [†] |
| 80 40 30 20 15 10 m | $\lambda/2$ at 3,440 MHz | 200 Ω | 20,0% (29,3%) | 220 pF + 4,95 μ H |
| 40 20 15 10 m | $3 \times \lambda/2$ at 21,224 MHz | 200 Ω | 40,5% | |

Table notes:
 * The open end of the antenna corresponds to 0% offset, the middle of the dipole to 50%.
 †

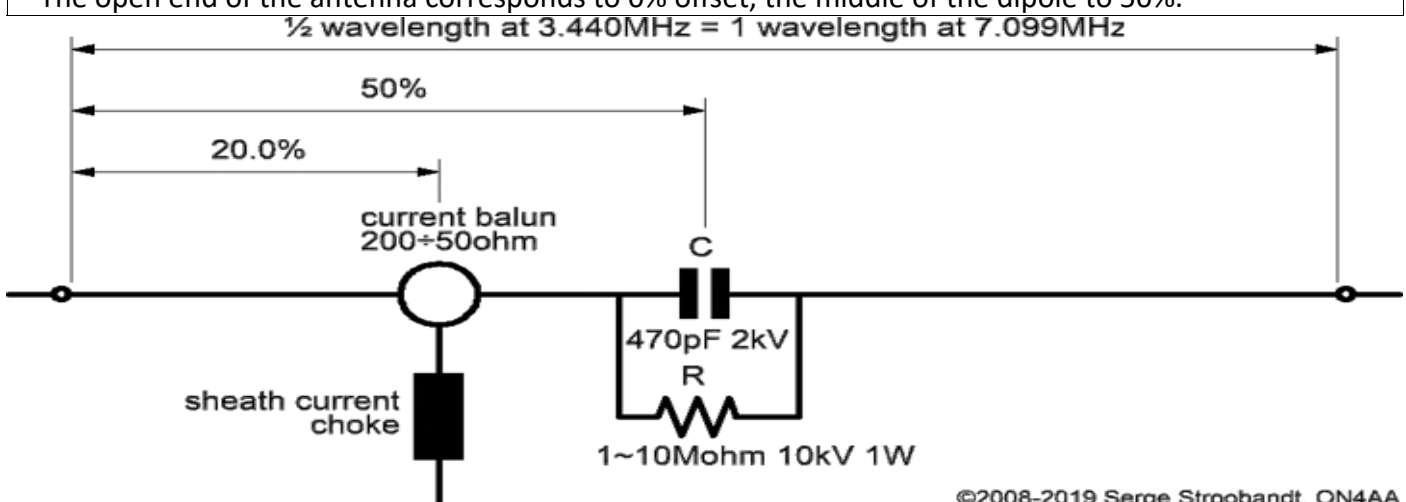

©2008-2019 Serge Stroobandt, ON4AA

Figure 11. CL-OCFD with 80, 40, 20, 15, 12 and 10 m coverage

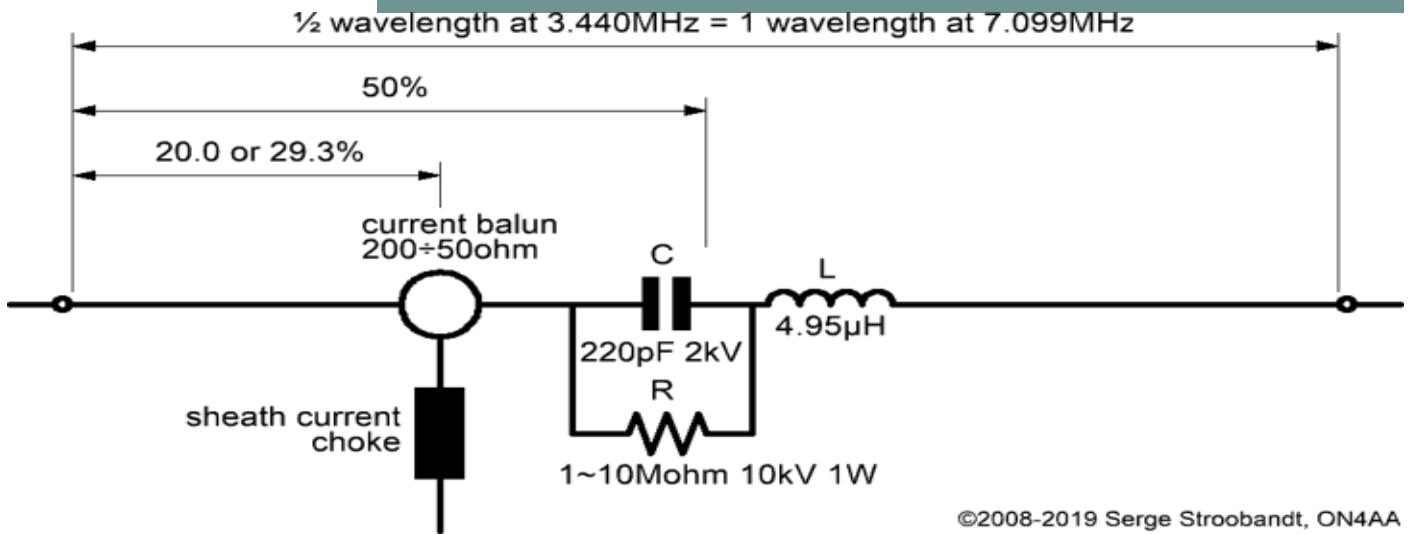

Figure 12. CL-OCFD with 80, 40, 30, 20, 15 and 10 m coverage

ON4AA-200 CL-OCFD @16.75m: VSWR @80m

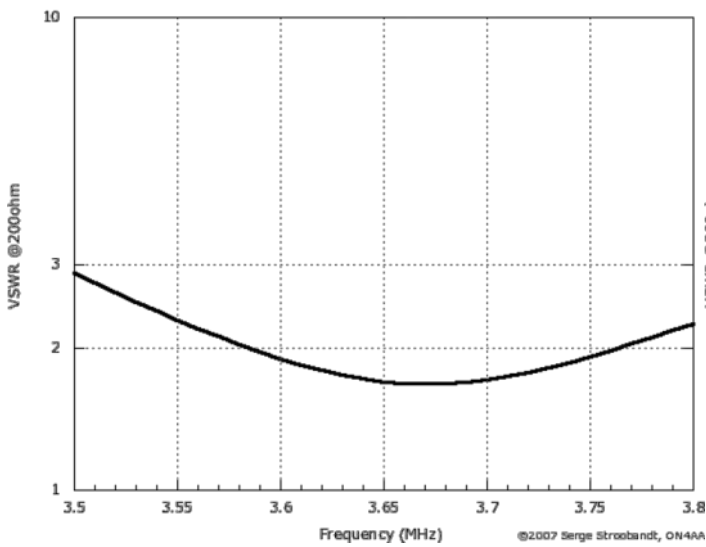

Figure 13. VSWR of the six-band 200 Ω CL-OCFD with 28,9% offset on 80 m

ON4AA-200 CL-OCFD @16.75m: VSWR @30m

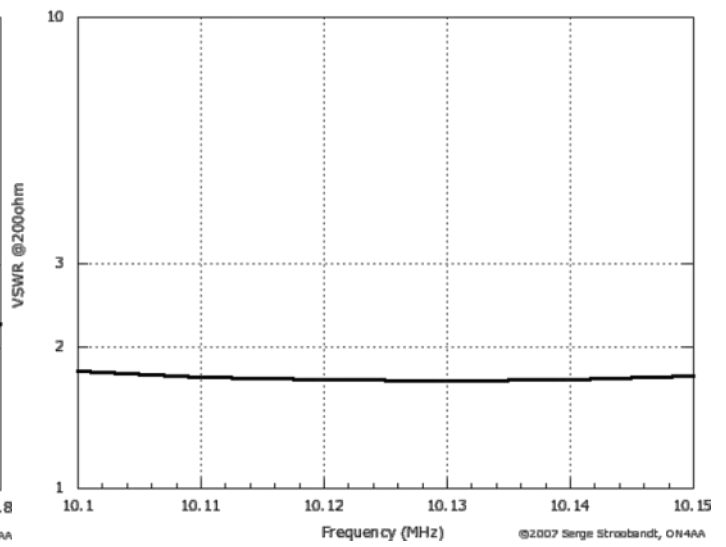

Figure 15. VSWR of the six-band 200 Ω CL-OCFD with 28,9% offset on 30 m

ON4AA-200 CL-OCFD @16.75m: VSWR @40m

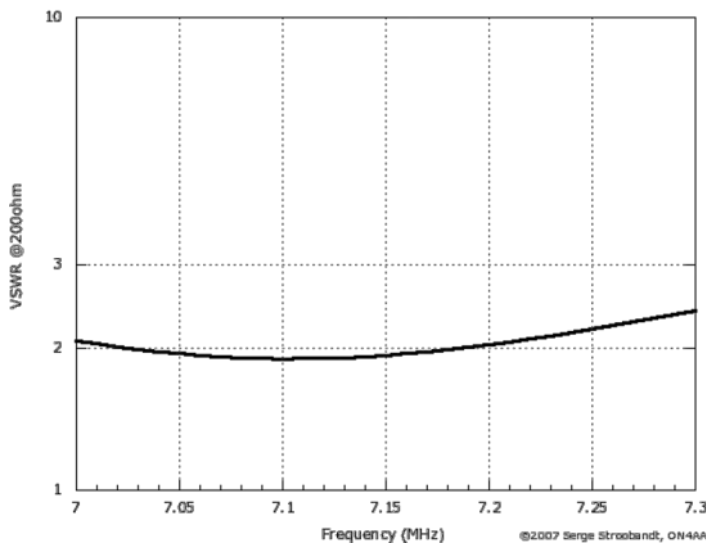

Figure 14. VSWR of the six-band 200 Ω CL-OCFD with 28,9% offset on 40 m

ON4AA-200 CL-OCFD @16.75m: VSWR @20m

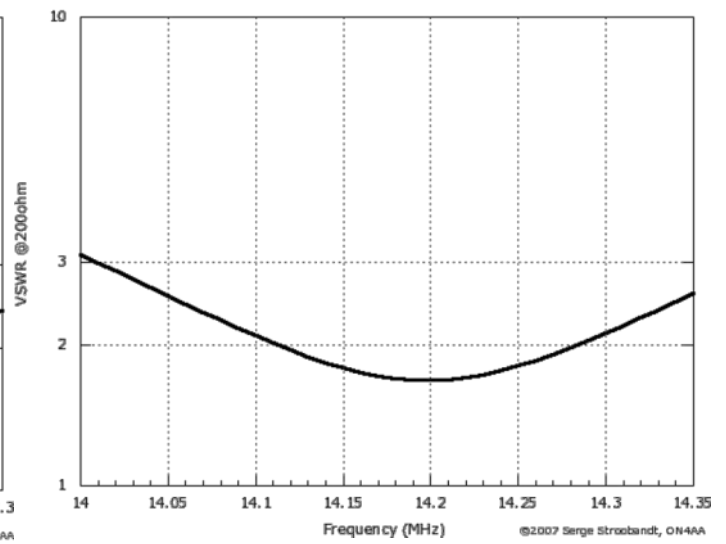

Figure 16. VSWR of the six-band 200 Ω CL-OCFD with 28,9% offset on 20 m

Radio ZS

RigExpert



RigExpert distributors since 2015 We endeavour to beat any price!

Try us for any hand tools, power tools, soldering equipment and measuring equipment, as well as all related consumables. Dedicated onsite factory making rucksacks and toolbags for technicians.

Agents for Bosch, Ryobi, Makita, DeWalt, Weller, Magnum, etc.



www.hottools.co.za

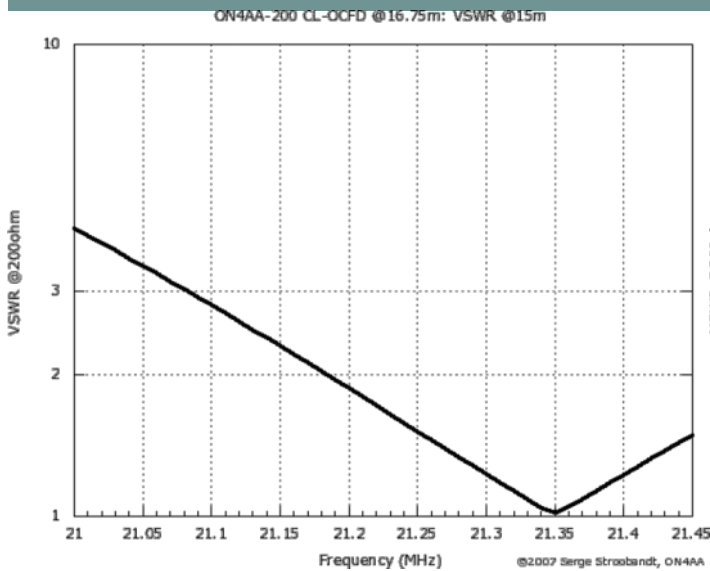

Figure 17. VSWR of the six-band 200 Ω CL-OCFD with 28,9% offset on 15 m

(Off-Centre-Fed Dipoles from page 111)

VSWR spectrum sweep

The six-band 200 Ω CL-OCFD with 28,9% offset was also modelled 16.75 m (55 ft) above good RF ground ($\sigma = 10\text{mS/m}$; $\epsilon_r = 14$) using EZNEC.

Modelling with EZNEC

Here is the [EZNEC input file](#). The model employs real ground in the near field of the antenna; not perfect MININEC ground. A [4nec2_model](#) is also available.

From comparison with previous modelling above very poor city ground, one may conclude that, at least at a height of 16,75 m (55 ft), VSWR is hardly influenced by ground quality. Furthermore, EZNEC in comparison to 4nec2 indicates that the antenna needs to be slightly longer, namely: 40,812 m. Anyhow, a fail-proof [trimming procedure](#) will be presented further on.

Radiation patterns

The following 72 power gain patterns in dBi were obtained using 4nec2 and good RF ground ($\sigma = 10 \text{ mS/m}$; $\epsilon_r = 14$). The [4nec2 input file](#) is available for [download](#).

Height

Focusing on the lower bands, the most interesting radiation patterns are obtained with an antenna height of about 16,76 m (55 ft). With the antenna at this height:

- On 80 m, the pattern combines maximum gain in the zenith for near-vertical incidence

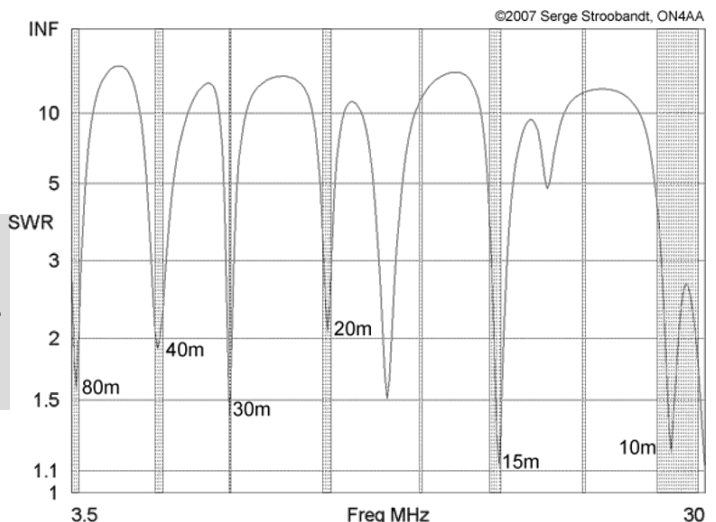
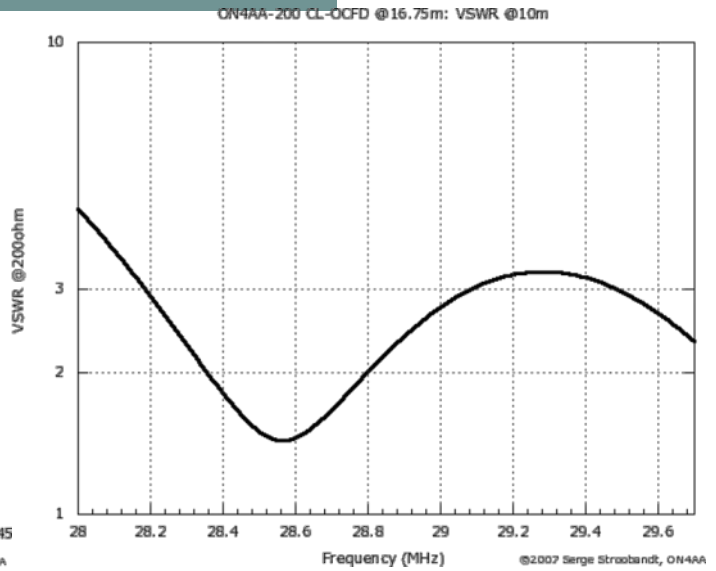

Figure 19. VSWR of the six-band 200 Ω CL-OCFD as a function of frequency

skywave (NVIS) short-haul communications with still enough broadside gain at 30° elevation for long-haul DX contacts.

- On 40 m, a take-off angle of 34° is sufficiently low to enable reliable long-distance (DX) contacts in all directions except for two broadside nulls.
- The 30 m-band is actually the main reason for choosing an antenna height of 16.76 m (55 ft). Only at this height, the useless zenith lobe will be suppressed.

It is also interesting to see how nulls in certain directions on one band are covered by increased gain lobes on the next harmonic band. This holds true for all six bands. So, one may conclude that the antenna offers spatial diversity through its

(Continued on page 121)

80 m-band radiation patterns



Figure 20: 80 m-band or fundamental resonant current distribution

Table 6: 80 m-band radiation patterns in function of height above good ground
($\sigma = 10 \text{ mS/m}$; $\epsilon_r = 14$)

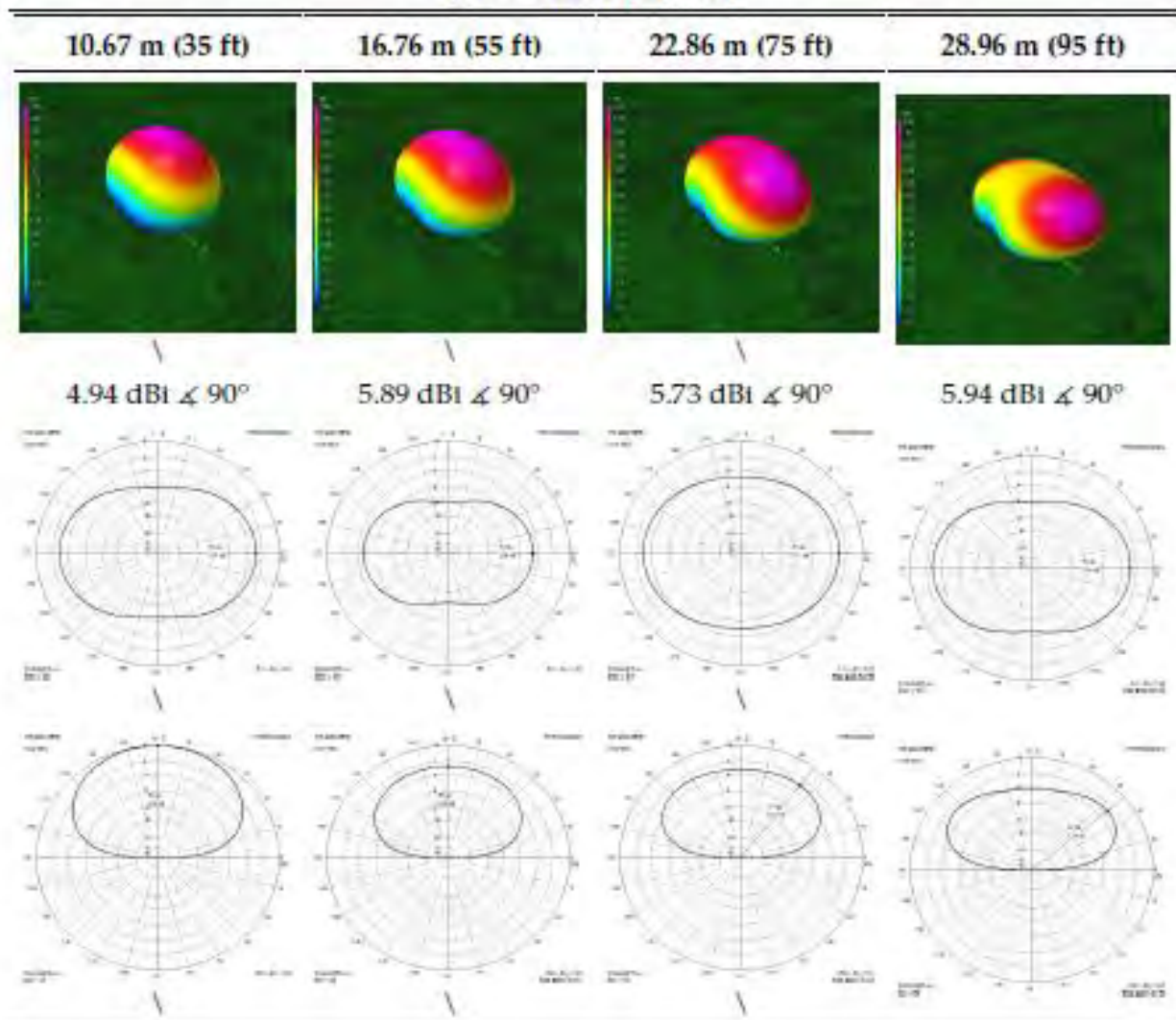

40 m-band radiation patterns



Figure 21: 40 m-band or second harmonic current distribution

Table 7: 40 m-band radiation patterns in function of height above good ground ($\sigma = 10 \text{ mS/m}$; $\epsilon_r = 14$)

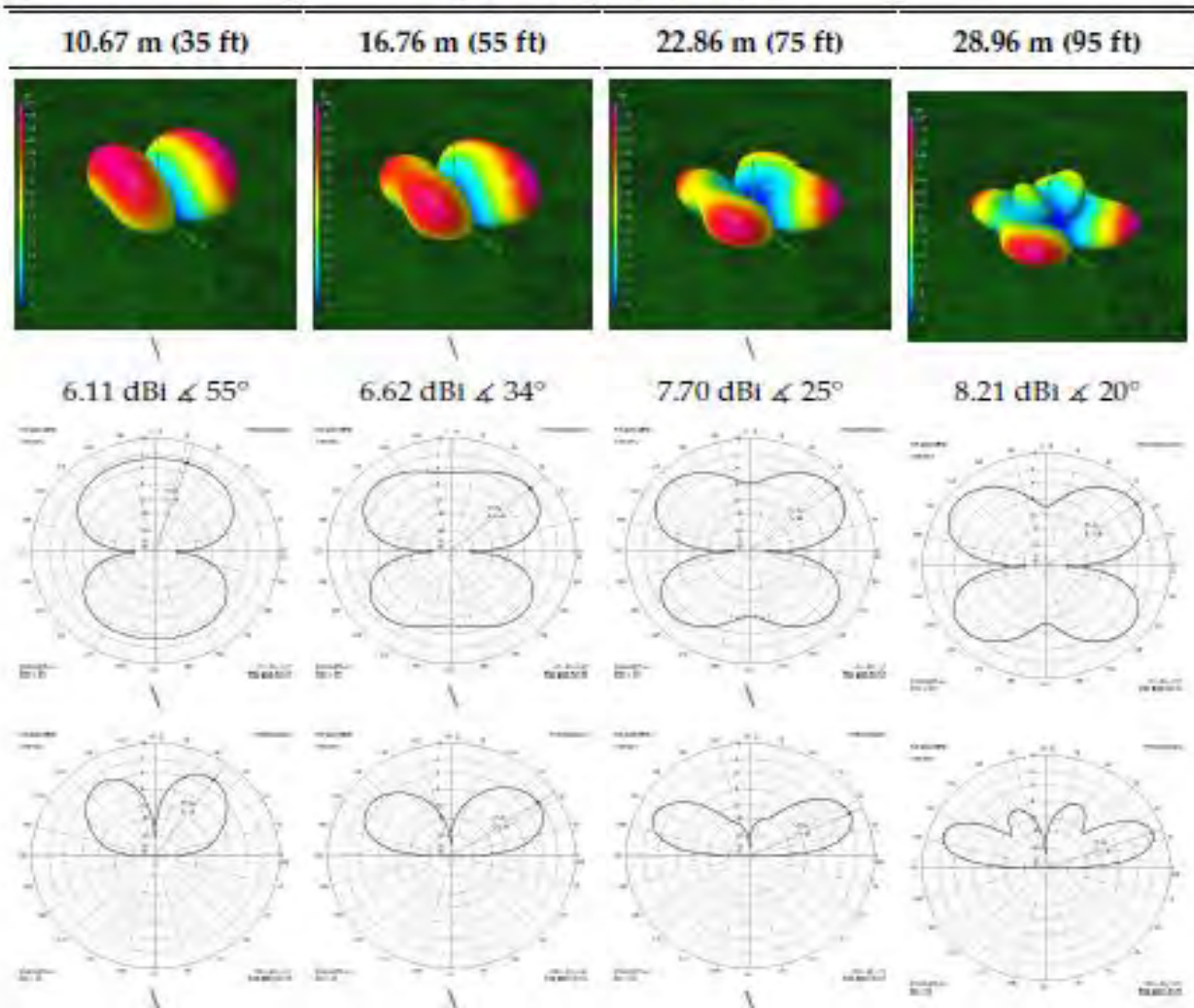

30 m-band radiation patterns



Figure 22: 30 m-band or third harmonic current distribution

Table 8: 30 m-band radiation patterns in function of height above good ground
($\sigma = 10 \text{ mS/m}$; $\epsilon_r = 14$)

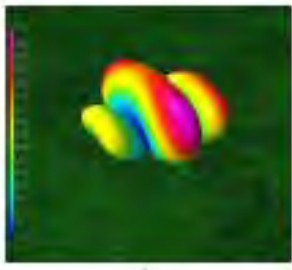
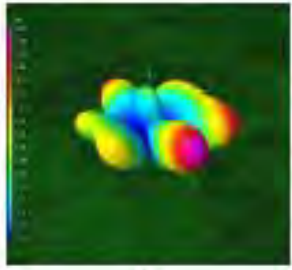
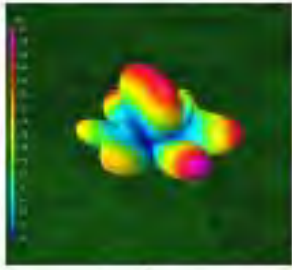
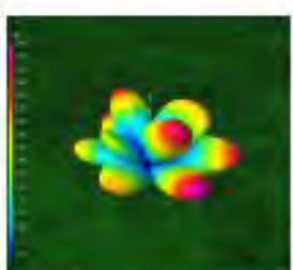
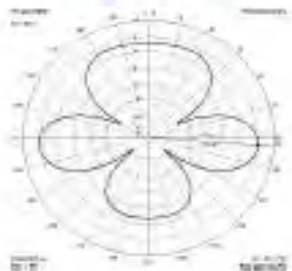
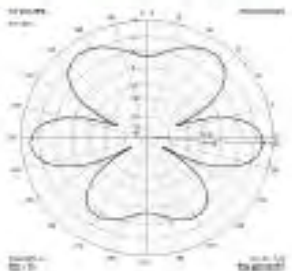
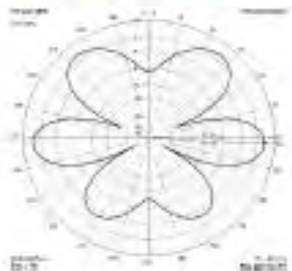
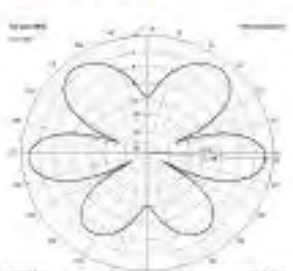
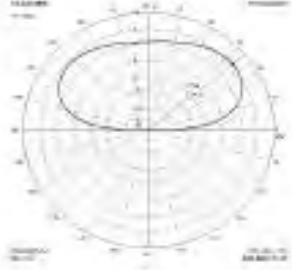
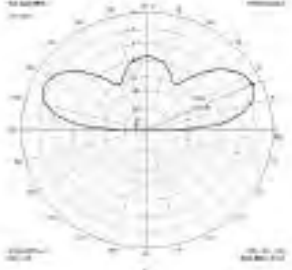
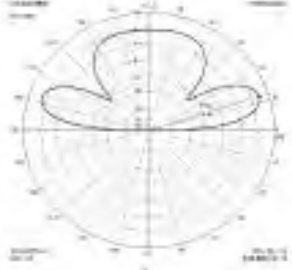
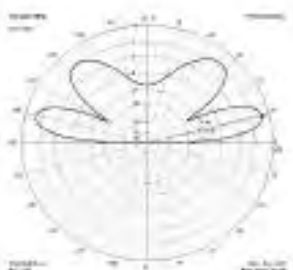

| 10.67 m (35 ft) | 16.76 m (55 ft) | 22.86 m (75 ft) | 28.96 m (95 ft) |
|---|---|--|---|
|  |  |  |  |
| 7.34 dBi \sphericalangle 40° | 8.44 dBi \sphericalangle 25° | 8.40 dBi \sphericalangle 18° | 8.83 dBi \sphericalangle 14° |
|  |  |  |  |
|  |  |  |  |

20 m-band radiation patterns

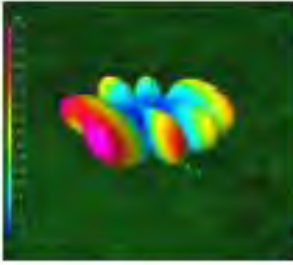
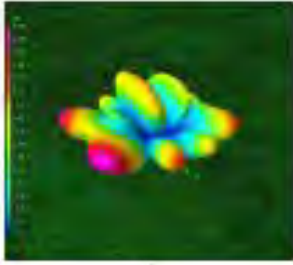
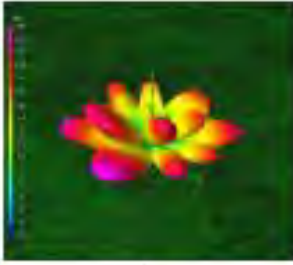

Figure 23: 20 m-band or fourth harmonic current distribution

Table 9: 20 m-band radiation patterns in function of height above good ground ($\sigma = 10 \text{ mS/m}; \epsilon_r = 14$)

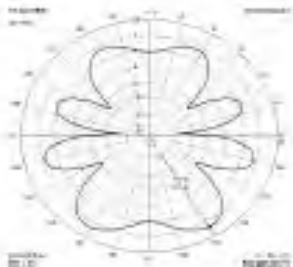
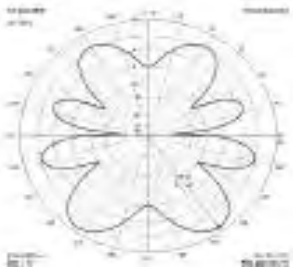
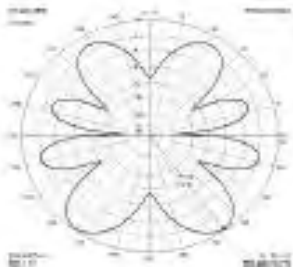
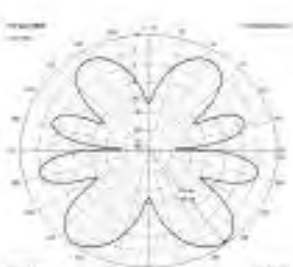
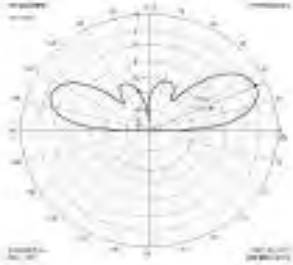
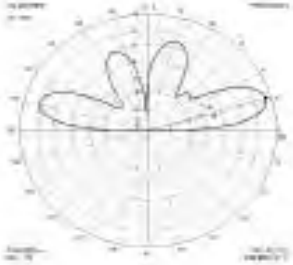
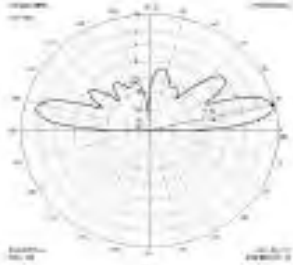
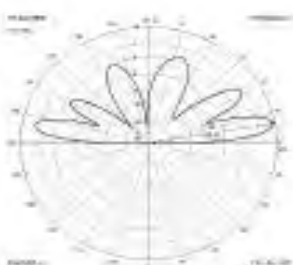
| 10.67 m (35 ft) | 16.76 m (55 ft) | 22.86 m (75 ft) | 28.96 m (95 ft) |
|---|---|--|---|
|  |  |  |  |
| 8.17 dBi $\angle 25^\circ$ | 9.17 dBi $\angle 17^\circ$ | 9.70 dBi $\angle 13^\circ$ | 9.65 dBi $\angle 10^\circ$ |
|  |  |  |  |
|  |  |  |  |

15 m-band radiation patterns

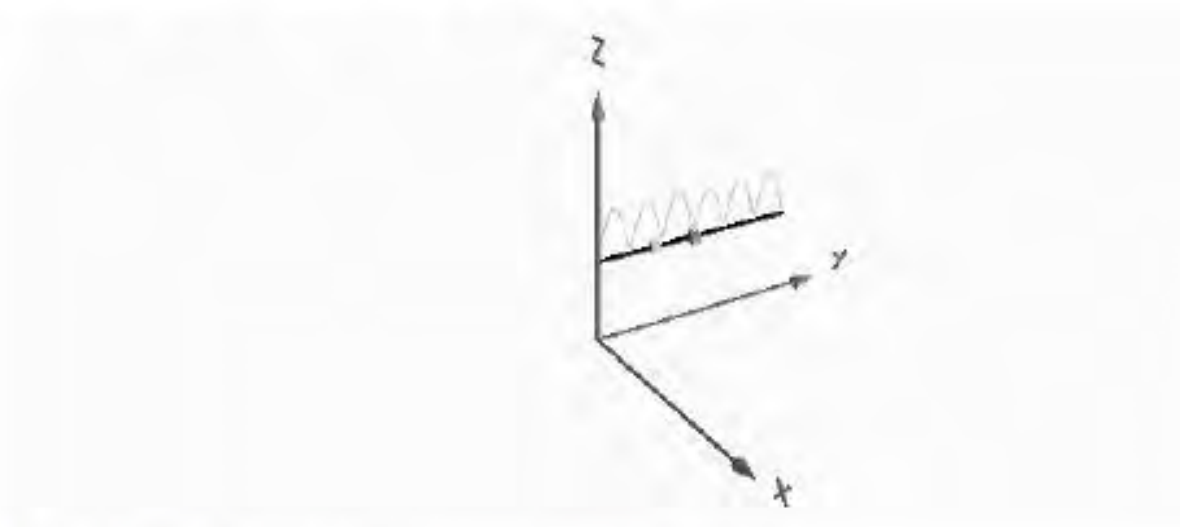

Figure 24: 15 m-band or sixth harmonic current distribution

Table 10: 15 m-band radiation patterns in function of height above good ground
($\sigma = 10 \text{ mS/m}$; $\epsilon_r = 14$)

| 10.67 m (35 ft) | 16.76 m (55 ft) | 22.86 m (75 ft) | 28.96 m (95 ft) |
|----------------------------|-----------------------------|----------------------------|----------------------------|
| | | | |
| 9.58 dBi $\angle 17^\circ$ | 10.56 dBi $\angle 11^\circ$ | 10.78 dBi $\angle 8^\circ$ | 10.97 dBi $\angle 7^\circ$ |
| | | | |
| | | | |

10 m-band radiation patterns



Figure 25: 10 m-band or eighth harmonic current distribution

Table 11: 10 m-band radiation patterns in function of height above good ground
 ($\sigma = 10 \text{ mS/m}$; $\epsilon_r = 14$)

| 10.67 m (35 ft) | 16.76 m (55 ft) | 22.86 m (75 ft) | 28.96 m (95 ft) |
|------------------------|-----------------------|-----------------------|-----------------------|
| | | | |
| 10.77 dBi \angle 13° | 11.46 dBi \angle 8° | 11.80 dBi \angle 6° | 11.87 dBi \angle 5° |
| | | | |
| | | | |

(Off-Centre-Fed Dipoles from page 114)

frequency diversity. Careful selection of operating time and frequency, taking into account available propagation modes, will put you in contact with any place on the globe. This is quite a lot for such a simple, yet very effective, broadband trap less antenna!

A final warning: As with any antenna, be very careful about placing it in the vicinity of other resonant metallic structures (especially antennas) since this may severely upset the desired radiation patterns.

Balun and choke

In theory, the CL-OCFD antenna can be fed with low loss balanced 200 Ω transmission line of any length without any further precautions. Unfortunately, 200 Ω twin line is not commercially available. Moreover, it requires closely spaced wires, which is [very hard to construct](#). If more convenient 50 Ω coax is used as a feed line, the antenna feed point will need to perform three additional tasks:

1. Transform the 50 Ω feed line impedance to 200 Ω . This will keep the SWR on the coaxial line below 3:1, limiting **reflection loss** and hence eliminating the need to use an open wire feed line.
2. Convert the unbalanced currents of the coax to balanced currents, as required by this symmetrically fed antenna. Failing to do so, would severely upset the radiation patterns
3. Prevent both conducted and induced RF currents from flowing back on the outer sheath of the coaxial line towards the shack. Doing so, will eliminate the most common source of radio frequency interference (RFI) occurring with off-centre-fed dipole antennas.

Current balun

Tasks 1 and 2 can be performed by a 4:1 impedance-transforming balun, preferably of the current-type. Voltage type baluns also work but will be less effective in forcing the right currents on the antenna when nearby metallic objects couple with the antenna. However, do avoid autotransformers or ununs having a common rail between input and output, but lacking a centre tap to earth. Here is [more information about selecting the right current balun](#).

A balun for an OCFD needs to have a high power-rating because it will need to handle the compounded effects of forward power, reflected power and sheath current. The same holds for the sheath current choke. In terms of the power handling capacity as stated on commercial baluns, beware that 1 kW SSB is less than 1 kW CW, is less than 1 kW RTTY, due to the increasing du-ty cycle of each respective mode. The use of a balun built within a tuner is not recommended because all too often, such baluns happen to be too flimsy. Furthermore, digital modes and FM have duty cycles of up to 100%. This meaning that if you want to operate full legal power in a digital mode, you really would like to have a balun rated at 5 kW CW/SSB.

If you happen to live in the USA, I highly recommend [dual Guanella element model 4115ocf](#) or [hybrid Guanella–Ruthrof f model 4116ocf](#) both of *Balun Designs*. I do not recommend using a single Guanella element on dual core, like model 4114ocf.

Whereas prohibitive import taxes render the [ON7FU Ferrite Applications 4:1 dual element Guanella balun](#) a more valuable choice of equal quality for EU citizens.

These baluns are devotedly hand-assembled by respectively [Robert J. Rumsey, KZ5R](#) and [Hugo Cnudde, ON7FU](#). I particularly like models with the N-connector option.



Model 4115ocf

(Continued on page 122)

(Off-Centre-Fed Dipoles from page 121)



Sheath current choke

In many practical realisations of off-centre-fed antennas, the third feed point task of preventing the flow of RF currents on the outer sheath of the coax is of-ten overlooked. This is how OCF antennas gained an unfair reputation of being provokers of RFI. Although a current balun will effectively prevent conduct-ed RF currents from flowing along the outer sheath of the coax, it may not al-ways be sufficient to prevent the antenna itself from inducing sheath currents on the coax line. Off-centre-fed antennas are more prone to this effect because the coax line is positioned asymmetrically with respect to the antenna.

Induced sheath currents can easily be prevented. Simply place a [sheath current choke](#) right behind the balun. Sheath current choke [construction instructions](#) are readily available.

Another sheath current choke may be mounted at the grounded coax bulk-head. This sheath current choke is optional. A coax bulkhead is a grounded metal entry plate through which coaxial lines enter the shack. Such a grounded coax bulkhead is also an excellent lightning protection. It may act as a diversion of last resort for any high currents on the outer sheath of the coax.

Because of their only moderately high sheath impedance, sheath current chokes are [only](#)

[effective when placed at locations where sheath currents require a relatively low impedance to flow.](#)

A sheath current choke at any of these locations will introduce, with its lossy magnetic material, a new boundary condition, preventing sheath currents to exist.

Centre load components

Capacitor

The table below lists, for an input power of 2 500 W, the voltage over the centre-loading capacitor at the different operating frequencies.

door-knob capacitor

For the six-band design (220 pF), the highest voltage is 1 310 V and is present when the antenna is operated at 10,125 MHz. If the power were only 150 W, the maximum voltage over the 220-pF capacitor would still measure 321 V. At 5 W this would be 59 V. A doorknob capacitor with a voltage rating of at least 2 kV can safely be employed in the six-band design operated at the 2,5-kW power level.

| f (MHz) | U220 pF | U478 pF |
|---------------|----------------|---------|
| 3,647 | 464 V | ? |
| 7,099 | 62 V | ? |
| 10,125 | 1 310 V | — |
| 14,174 | 209 V | ? |
| 21,224 | 403 V | ? |
| 28,594 | 652 V | ? |

Many European surplus doorknob capacitors are Russian made. Picofarad in the Cyrillic alphabet is denoted as пФ. The Cyrillic letter n may appear to Westerners as a Latin n of nano, but in reality, it is a Cyrillic “pe” of pico. Kilo-volt in Cyrillic is written as κВ. There are more types of high-voltage capacitors; [read about them here.](#)

Some have also successfully employed a bank of parallel high-voltage SMD capacitors as a capacitive centre load. However, replacing the discrete capacitor with an open stub line would be ill-advised.

An open stub line may have the exact same capacitance at its design frequency; on other frequencies it will behave completely differently,



Figure 26. A W2DU sheath current choke prior to applying heat shrink.

(Continued on page 123)



Left - Figure 27. A doorknob capacitor with its snubber resistor installed inside a protective inverted egg cup. The egg cup is made of a durable, weather-resistant plastic. The whole is attached to an antenna insulator.

Right - Figure 28. Layout for mounting a doorknob capacitor with its snubber resistor to an antenna insulator. All hardware is A2 stainless steel with an M5 thread.

(Off-Centre-Fed Dipoles from page 122)

upsetting the desired resonances of the antenna.

Snubber resistor

The centre-load capacitor C needs to be protected against breakdown from static charges. A [10 kV 1 W thick film metal oxide resistor \$R\$ of about 1 to 10 M \$\Omega\$](#) will bleed off any static electricity without incurring any significant loss. Such a protective resistor is also called a [snubber](#).

Inductor

An inductor of 4,95 μH can take on many sizes and shapes. However, the loss and hence quality factor of an inductor will to a certain extent be dependent on its form factor and conductor size. Coils with a form factor that would fit inside a cube often yield the highest quality factor for a given conductor size. Eventually, many designs are a compromise between size, weight and Q factor.

Since I was not satisfied with the accuracy and formulas on which most inductance calculators are based, I designed my own [inductance calculator](#), especial-ly for this project. However, feel free to employ it also for any of your other projects.

Here is a design suggestion for the 4,95 μH centre-loading inductor of the six-band CL-OCFD:

According to my [inductance calculator](#), an air coil of length $\ell = 150$ mm with a mean diameter $D = 150$ mm and $N = 6,75$ turns of diameter $\frac{1}{4}$ " ($d = 6,35$ mm) copper brake pipe will yield an inductance of 4,98 μH at 10.125 MHz; close enough for this application. With these dimensions the unloaded quality factor $Q_{L,ul}$ will be a staggering 2220!

The self-resonant frequency of this coil is 31,633 MHz. This is well away from the highest used odd harmonic, 10,125 MHz in this case. (Remember, even harmonics are not influenced by the centre-load!)

As for the coil's construction technique, I prefer [AD5X's plumbing recipe](#).

Insulators and rope

Insulators

Amateurs tend to forget about the high RF potentials that are present at the ends of any dipole antenna. Cheap, poor, dirty or broken insulators may form through humid hang ropes an additional path to earth or at least lower the resonant frequencies. The resistance of such a path may be of the order of mega-ohms. Nevertheless, due to the equally high end-potentials these hidden losses can become quite considerable!

Rope, knots, pulley and weight

Horizontal wire antennas are often hung from ropes on both ends. Due to gravitation, flexible wires will hang in the shape of a catenary which corresponds to the graph of a hyperbolic cosine; $\cosh(x)$. Considerable tensile forces are required to straighten up the wire a bit. On a stormy day, the wind force may put extra strain on the wire, eventually causing it to snap. A pulley with weight system at one end of the antenna will prevent this from happening. A pulley system will also greatly



(Continued on page 124)

(Off-Centre-Fed Dipoles from page 123)

simplify the trimming of your antenna for resonance as well as general antenna maintenance.

[Click here](#) for:

- ◆ More information on rope types for outdoor use,
- ◆ Saving money on stainless steel clamps by knowing some useful knots.

Trimming

How long does the antenna wire need to be?

Above question often returns in many antenna news-groups. Well, my antenna is actually 40,66 m long, because it is made of [4 mm² gauge PVC-insulated wire](#) and hanging at a height of 16,75 m above a city lot ($\sigma = 1 \text{ mS/m}$; $\epsilon_r = 5$). There is a good chance your antenna will end up measuring a different length. It will most probably be hanging at a different height and could be made of another (bare?) wire gauge. Moreover, your location will have different ground characteristics. Look here for a [ground-conductivity map](#) of your area. As a result of these influencing factors, your CL-OCFD antenna will probably need to be slightly longer or shorter.



Trimming a wire antenna may seem daunting at first, but as a matter of fact it is absolutely necessary! **Any HF antenna - except for a log-periodic - requires element length trimming to compensate for its height above ground.** Do not be led fooled by other antenna designs not mentioning this. The need may be less stringent with thick tub-ing elements, but there are examples abound where it does pay off to even trim very thick elements.⁹

At what frequency should the antenna wire resonate?

That is a far better question. Here is a universal answer:

The electrical length of the CL-OCFD, at its definitive location and height, should be such that its fundamental resonant frequency is exactly 3,440 MHz. (See the [section about resonant lengths](#)). This resonance is measured at the centre of the antenna without the centre-loading inserted.

Note that this trimming requirement is not exclusively reserved for this antenna. All horizontal HF wire antennas require trimming to adjust to the surroundings. Most manufacturers prefer not to mention this.

The resonance of the antenna wire needs to be checked with the antenna wire at its definitive height and location. The antenna will need to be temporarily fed at its centre with the same sheath current choke. This is the very same sheath current choke which will be used later on at a different position along the antenna.

There remains one problem though: How to determine the fundamental resonance of a dipole at 3,440 MHz when it is hanging at a great height above the ground?

At its fundamental resonance, the antenna will have a radiation resistance of 73 Ω . This value coincides with the input impedance when the antenna is temporarily fed at the centre. However, when feeding over a test coax of differing characteristic impedance, one will not see resonance even though the antenna is resonating! The happens because the mismatch will add some reactance. See for yourself with [AC6LA's transmission line calculator](#). Lowering the di-pole is neither an option as this will lower its resonant frequency. Here is how to overcome this dilemma...

Using a vector network analyser

Beware! There are little black boxes on the market, pretending to be VNAs. However, many of these little boxes do not offer the possibility to calibrate with a 50 Ω load, a short and an open. **If it does not calibrate, is not a vector network analyser!** Do not spend any money on this.

A brief guide about [using a noise bridge or SWR analyser](#) is available for those not having a VNA at their disposal.

Using a VNA with Bluetooth connectivity

The mini-Radio Solutions miniVNA PRO is an affordable vector network analyser (VNA) offering remote wireless operation over Bluetooth. This allows for measuring HF antennas installed at height without having to deal with coax cable lengths, baluns nor common mode suppression

(Continued on page 125)

(Off-Centre-Fed Dipoles from page 124)

chokes. In case of the CL-OCFD, this VNA is able to determine its fundamental resonant frequency at the centre, as well as the centre load reactance required for resonance on 3,647 and 10,125 MHz.

A separate article details how to modify [the miniVNA PRO to render it truly field proof](#).

Using a VNA with a random length coax line

All what needs to be done, is preparing an open (i.e. nothing), a short and a 50 Ω resistive load that can connect to the terminals of the sheath current choke at the end of the random length coax line. If your choke has wire terminals, the 50 Ω calibration load may be constructed out of two high-precision low-inductive 100 Ω resistors. Connect the sheath current choke to a long coax cable and connect the arrangement to the VNA. Hit the calibration button and you are ready to start trimming the antenna at its definitive height.

Trimming procedure

There are two ways of trimming the antenna. The first method was suggested to me by [Bob Rose, KC1DSQ](#). This trimming method requires the antenna wire to be intact at its centre. By contrast, the alternative trimming method starts off with the dipole cut at the middle.

Trimming for 7,099 MHz resonance at the 20% feed location

1. Start with a slightly too long stretch of antenna wire; say 42 m long.
2. Cut the wire at 20%; its intended feed point location.
3. Leave the 50% centre of the antenna intact.
4. Connect a VNA calibrated at 200 Ω at that feed point.
5. Trim the antenna for the lowest return loss (SWR) at 7,099 MHz and the other even harmonics, i.e. 14.174 MHz, 21.224 MHz and 28.594 MHz. For each amount of length trimmed off the short end, trim four times that length off the long end.
6. Once finished trimming, temporarily reconnect the short and long end.
7. Only now, cut the antenna at its 50% centre.
8. Connect the VNA now at this centre location to determine the required reactances for

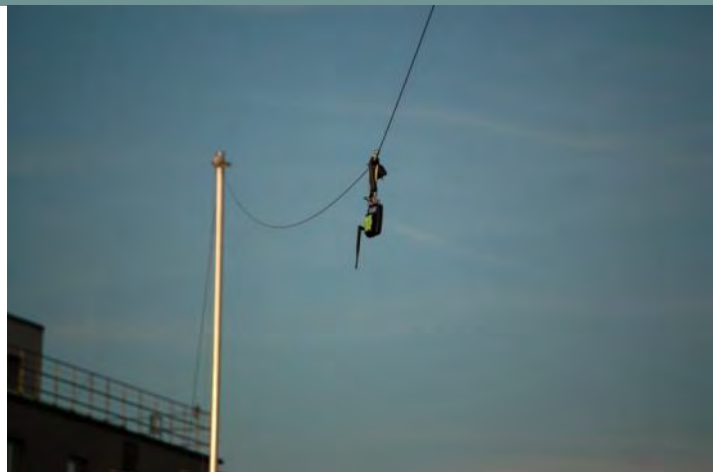

Figure 29: A modified miniVNA PRO hanging from the centre of a HF dipole at about 15 m (50 ft) above ground. A balun is not required for taking accurate measurements. The VNA can be read from the comfort of my home even though there are quite some 2,4 GHz WLAN signals present in this urban environment. Two 3350 mAh Panasonic NCR18650B Li-ion cells in parallel provide more than enough «juice» for a whole day of measurements.

resonance at 3,647 MHz and 10,125 MHz.

The advantage of this approach is that it does not rely on any modelling results (i.e. the 3,44 MHz). All measurements are taken at the frequencies of interest.

Trimming for 3,44 MHz resonance at the centre

1. Start off with an [antenna wire](#) with a length of 42 m. During this process, stick to the rule: «Better having a wire that is too long, than one that is too short!»
2. Prepare, as described in the previous section, a half-wave length of test coax (or multiple thereof), resonant at 3,440 MHz. Connect this test coax to the sheath current choke. Alternatively, connect an arbitrary length of test coax to the sheath current choke and calibrate this arrangement with a VNA.
3. Cut the antenna wire in the middle. The following may sound too obvious; but for those who do not know: the middle of a long wire is found by folding it in two.
4. Connect the test coax with the sheath current choke at the centre of the antenna.
5. Do not connect the centre load nor the balun!
6. Hang the antenna at its definitive height and

(Continued on page 126)

(Off-Centre-Fed Dipoles from page 125)

- location. Measure the impedance at 3,440 MHz. It should have a positive (i.e. inductive) reactance. This means the antenna is too long for resonance at this frequency. Now, try to find this first lower frequency where the antenna resonates. It should be somewhere below 3,4 MHz. This will give you a feel of what we are looking for at 3,440 MHz. Write down this lower resonant frequency.
7. Lower the antenna. —This is why it is handy to have a pulley installed.— Trim off an equal amount of both antenna legs. Use this [trimming chart](#). If you have only one pulley, you may trim the antenna also at its centre. Keep note on paper of how much you have been cutting off so far. At this point, the clever wannabes amongst you, would say they can predict how much wire needs to be trimmed off in total. Don't be fooled in cutting off too much! It is not a linear process, so take it step by step.
 8. Repeat steps 6 and 7 until you find resonance (reactive part $X = 0$) at 3,440 MHz. Normally, you should also be able to measure the 7th resonance in the vicinity of 24,912 MHz.
 9. With the antenna still hanging in the air, measure the reactance at 3.647 MHz and 10.125 MHz. Check if they are more or less equal but opposite in sign of the values listed for X_{CL} at these frequencies. If not, you may want to adapt the values of C and L to your specific case. This only applies to users of VNAs and well-designed noise bridges. Measurements made with SWR analysers are not reliable.
 10. Now, you may lower the antenna a final time. Remove the sheath current choke from the centre.
 11. Measure 28,9% of the total(!) antenna length and cut the antenna at this point. Take great care in measuring this length accurately, because the VSWR-performance of this antenna is quite sensitive to its relative feed point location. Insert the 4:1 current balun immediately followed by the sheath current choke at this position.
 12. Connect the centre-loading network at the centre of the antenna.

13. Raise the antenna, warm up your tube amplifier, tune a little and have fun!

Summary

VSWR performance of ordinary off-centre-fed dipoles is always a trade-off between either excellent broad-band performance on 80 m combined with mediocre VSWR on the higher amateur HF bands or vice versa. This problem is due to the fact that the higher amateur HF bands are not true harmonics of the 80 m band.

To overcome this problem, the novel concept of centre-loading an off-centre-fed dipole (CL-OCFD) is introduced. Centre-loading offers independent control over a dipole's fundamental resonant frequency and odd harmonics, whilst off-centre feeding ensures low-VSWR coverage of the entire 80 m-band.

Two practical CL-OCFD designs with useful radiation patterns are presented. A five-band design (80, 40, 20, 15 and 10 m) employs a capacitive centre-load of 470 pF, whereas a six-band design adds 30 m-band coverage by replacing the centre-load by an 4,95 μ H inductor in series with a 220-pF capacitor. These designs are not scalable to other bands.

Publications

The centre-loaded off-centre-fed dipole is the original invention and work of Serge Stroobandt, ON4AA. After its initial publication on the *Internet* in 2007, the CL-OCFD was subsequently described in the following publications:

Ed Spingola, VA3TPV. Multiband HF antennas, part 3, Windom and OCF dipole. *The Communicator*. Mississauga; 2010;13(4):9-11. Available at https://web.archive.org/web/20170518222728/http://www.marc.on.ca/Files/NewsLetters/MARC_NL_2010_04.pdf.

Alois Krischke, DJ0TR, Karl Rothammelt, *Antennenbuch*. 13th ed.. DARC Ver-lag GmbH, Baunatal; 2013:301-304. Available at <http://www.antennen-buch.de/>

A year after the online publication of my article, a description of a very similar CL-OCFD for 80 and 160 m was published, equally claiming full 80 m band coverage. There is no reference to my work. It appears to be completely independent work. The

(Continued on page 127)

(Off-Centre-Fed Dipoles from page 126)

antenna is actually a 3-band CL-OCFD antenna (160, 80 and 75 m) where the centre loading moves the natural third harmonic to the lower end of the 80 m band, below the 75 m second harmonic. Gene Preston, K5GP, A broadband 80/160-meter dipole. Available at https://www.egpreston.com/K5GP_broadband_80_meter_antenna.pdf

References

¹ John Belrose, VE2CV, Peter Bouliane, VE3KLO. The off-centre-fed dipole revisited: A broadband, multiband antenna. *QST*. 1990; 74(8):28 - 34. <https://www.arrl.org/files/file/protected/Group/Members/Technology/tis/info/pdf/9008028.pdf>

² Frank Witt, AI1H. How to design off-centre-fed multiband wire antenna using that invisible transformer in the sky. In: *Antenna Compendium Volume* The American Radio Relay League; 1992:66 -75. www.arrl.org/shop/Antenna-Compendium-Volume-3/

³ Gene Preston, K5GP. A broadband 80/160-metre dipole. Published 2008. www.egpreston.com/K5GP_broadband_80_meter_antenna.pdf

⁴ Karl Rothammel, Y21BK. *Antennenbuch*. 10th ed. (Alois Krischke, DJ0TR, ed.). Franckh-Kosmos Verlags-GmbH and Co., Stuttgart; 1991:159-162. <http://www.antennenbuch.de/>

(Contest News from page 54)

will you be able to talk with a handheld from the Hartbeespoort Cable Car or Naval Hill in Bloemfontein or from Table Mountain? Do you have an AMSATSA 2 m/70 cm Yagi? Park on your favourite hill, mountain or scenic viewpoint and make a few contacts

This contest is a great excuse to invite a friend along and enjoy a day out. Clubs, mobilise your novices and new radio amateurs for the day and get them calling CQ! This is the perfect opportunity to introduce your radio family to the excitement of VHF/UHF contesting. Points are collected for every kilometre based on the exchanged 6-digit grid locators you send and receive. It is FM mode only on the 6 and 2 metres and 70-centimetres. The contest runs from 10:00 to 13:00 UTC on Saturday 13 June.

The Winter ZS SOTA Activity Weekend

⁵ Fritz Spillner, DJ2KY. Die FD4-Windom-Antenne. *QRV Amateur-Radio*. 1971;25:13-20. <https://www.addx.de/textarchiv/archiv-grv.php>

⁶ Thomas Fichtlscherer. *Antennas for Shortwave*. Hofi HF-Technik GmbH and Co.KG, Mönchsroth; 2004. www.hofi.de/pdf/de/Draht_Antennen.pdf

⁷ Gian Moda, I7SWX. Technical topics. *RadCom*. 1988;64(3). <https://rsgb.org/main/publications-archives/radcom/>

⁸ Gian Moda, I7SWX. A coaxial-fed multiband 'Windom' antenna. In: Erwin David, G4LQI, ed. *HF Antenna Collection*. 1st ed. Radio Society of Great Britain; 1991:9. https://www.rsgbshop.org/acatalog/Online_Catalogue_Antennas_37.html

⁹ John Devoldere, ON4UN. *ON4UN's Low Band DXing: Antennas, Equipment and Techniques for DXcitement on 160, 80 and 40 Meters*. 5th ed. American Radio Relay League; 2010. <https://www.arrl.org/shop/ON4UN-s-Low-Band-DXing/>



This work is licensed under a Creative Commons Attribution-NonCommercial-ShareAlike 4.0 International License. Other licensing available on request.

Unattended CSS typesetting with 

This work is published at <https://hamwaves.com/cl-ocfd/en/>.

Last update: Monday, March 1, 2021.

Have you identified a summit or two that you want to activate for the Winter ZS SOTA Activity Weekend? This fun activity is open to all radio amateurs. The activity weekend takes place on Saturday 13 and Sunday 14 June with the Queens of the Mountain event for the YLs. Monday 15 June is a school holiday and Tuesday 16 June is a public holiday, so you can extend your SOTA activities over four days!



You will find all the rules for these three contests in the 2026 Contest Manual or on the Contest pages on mysarl.

Call us for the best *Hamradio* deals in SA



Daiwa CS-201
Low Loss two-way coax switch.

DC-30 MHz 1.5kW 150-600 MHz 500W. Insertion Loss DC-1000 MHz less than 0.12dB

R700.00 incl. vat.

Spiderbeam 12m

Fibreglass Telescopic Mast. Under 4kg portable weight.

1.2m collapsed. Ideal for Field Use – HAMNET, SOTA, POTA R3575 inc.

Daiwa CN-501H

1.8-150 MHz

15/150/1500W

Highly Accurate Cross-Needle SWR/Pwr Meter

Selectable Average or PEP Power Reading

R2495.00 Special Offer R2350.00 until 30 June 23



Diamond BU-50A 1:1 lightweight Balun. Power Handling 1.2kW covering 1.7-40MHz R750.00 inc. VAT

We are distributors for Alinco, Icom, Kenwood and Yaesu Transceivers. Please call for prices

SAM's Radio

011 802 2976 Email: Sam.ford@radioacc.co.za